

**User manual**

**DTH31 series high frequency UPS  
(10-20kVA)**

**厦门市爱维达电子有限公司**



**Please follow all warnings and operating instructions in this manual. Please keep this manual in a suitable location so that you can read the following precautions carefully before proceeding with installation. Please read all safety precautions and operating instructions before operating this product.**

# Table of contents

1. SAFETY AND ELECTROMAGNETIC COMPATIBILITY (EMC) RELATED CONSIDERATIONS .....	1
1-1. SHIPPING AND STORAGE .....	1
1-2. Preparation 1 _ 1_ 1_ 4on 24_ 53	

# 1. Safety and Electromagnetic Compatibility (EMC) Related Considerations

Please read the user manual and safety instructions carefully before installing and using this product!

## 1-1. Shipping and storage

 · When you need to transport this UPS system, be sure to wrap it in the original packaging materials to prevent and slow down accidental collisions.

 The UPS product must be stored in a dry and well-ventilated place.

## 1-2. Preparation \_

 · When this UPS system is sent directly from a cold environment to a warm environment such as indoors, condensation may occur. At this point, be sure to wait until it is completely dry before installing. For this reason, after moving to the installation site, please leave it for at least 2 hours to allow the UPS to adapt to the environment before installing it.

 This UPS system should never be installed near water or in a humid environment.

 This UPS system must not be installed in a place exposed to direct sunlight or near heaters.

 Never block or cover the ventilation holes in the UPS enclosure.

## 1-3. Installation \_

 Never connect equipment that can cause overload of the UPS ( such as high-power motor equipment ) to the output socket or terminal of the UPS .

 When routing power cords and other circuits , avoid areas where they may be stepped on or tripped over.

 Do not block or cover the ventilation holes on the UPS enclosure. The place where the UPS is installed must be well ventilated, and make sure there is enough ventilation space around the UPS host.

 This UPS is equipped with a grounding terminal, which is used to connect the external UPS battery room to form equipotential grounding after the system is installed.

 The installation of this UPS can only be carried out by professional maintenance personnel.

 In indoor wiring installation, appropriate circuit breaking equipment such as short-circuit protection circuit breakers should be added.

 In indoor wiring installation, a dedicated emergency switching device should be configured to stop the UPS and continue to supply power to the load equipment when needed , and is not limited to the operating mode of the UPS at that time.

 After completing the grounding first, connect it to the mains power supply terminal.

 Relevant installation and wiring must comply with relevant local electrical regulations.

1-4.  Connection notes

- There is no backfeed protection device installed inside this machine. Please install an isolation device before using this machine, and the isolation device must be able to carry the input current of this uninterruptible power supply system.

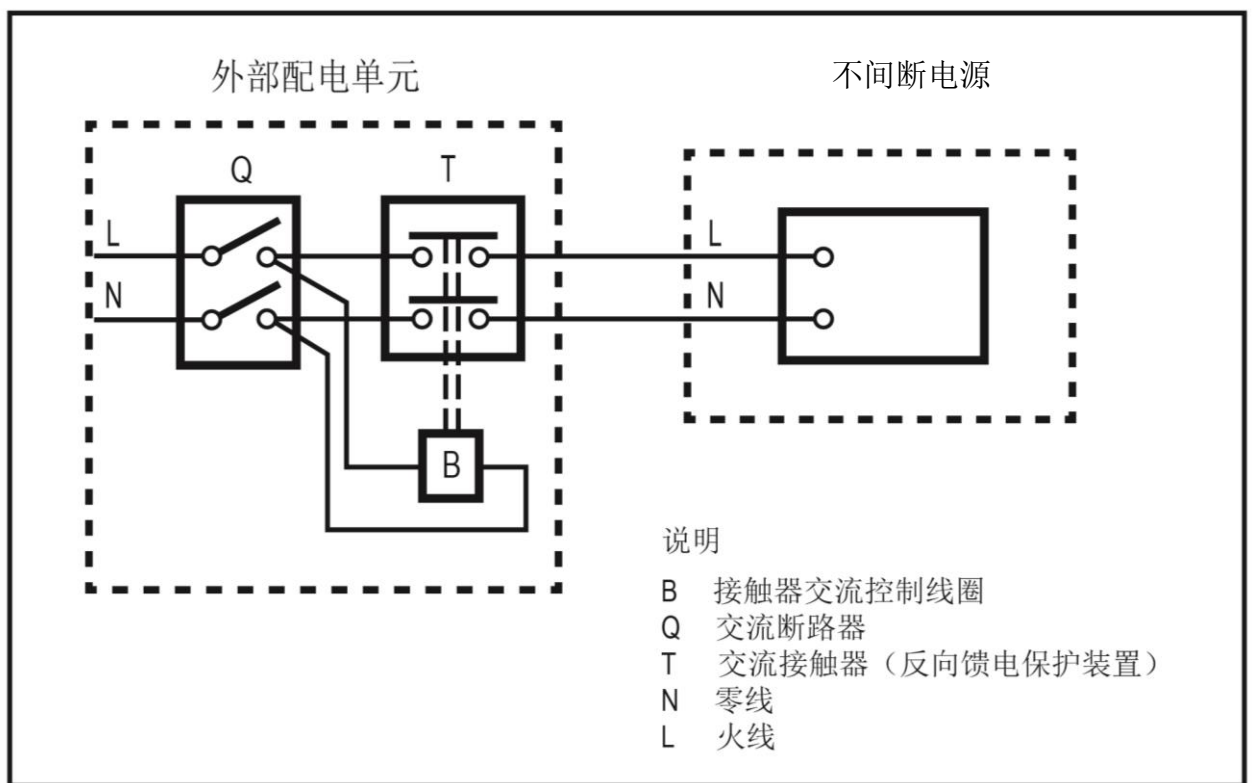

- This uninterruptible power supply system must be grounded.
- The input power terminal of this uninterruptible power supply system must be single-phase and grounded.
- It is not recommended that this uninterruptible power supply system be used for life-sustaining application instruments, because when this machine fails, it may cause these instruments to malfunction. Please do not use it in an environment where flammable gases are mixed with air, oxygen or nitrous oxide. use this machine.

•Please make sure that the output ground terminal of this uninterruptible power supply system is indeed connected to the ground wire.

•This uninterruptible power supply system will be connected to a DC power source (i.e. battery), so even if the UPS is not connected to the mains, the output terminal block may still be live.

<ul style="list-style-type: none"><li>- <b>Before servicing this circuit wiring</b></li><li>- <b>-Isolate the uninterruptible power supply system (UPS) first</b></li><li>- <b>-Then, perform hazardous voltage testing between terminals including the protective ground terminal, etc.</b></li></ul> <div style="text-align: center;"><p><b>Backfeed hazard</b></p></div>
--

## 1-5. Operation and use



Never disconnect the ground wire or mains connection terminal of the UPS at any time to avoid failure of the ground protection of the UPS system and load equipment.



This UPS system has an internal current source ( battery ) . Even if it is not connected to the mains power supply terminal, its output socket or terminal block may still be live.



In order to completely disconnect the UPS system, please press the <OFF> button first and then disconnect the main power supply.



Prevent liquid or other foreign matter from entering the UPS system.



The operation of this UPS system can be performed by inexperienced persons.

## 1-6. Standard \_

<b>* Security</b>	
IEC/EN 62040-1	
<b>*EMI</b>	
Transmission of radiation ..... :IEC/EN 62040-2	Category C3
Electromagnetic radiation ..... :IEC/EN 62040-2	Category C3
<b>*EMS</b>	
ESD..... :IEC/EN 61000-4-2	Level 4
R.S..... :IEC/EN 61000-4-3	Level 3
EFT..... :IEC/EN 61000-4-4	Level 4
SURGE..... :IEC/EN 61000-4-5	Level 4
CS..... :IEC/EN 61000-4-6	Level 3
Power frequency magnetic field ..... :IEC/EN 61000-4-8	Level 4
Low frequency signal ..... :IEC/EN 61000-2-2	
<b>WARNING</b> : This product is a second environment non-residential commercial and industrial product and additional precautions may be required to prevent interference.	

## 2. Installation and operation

This online (on-line) UPS is divided into two types: standard model and extended model. Both types can add the < Parallel control (Parallel)> function, and the installation and use of related functions will be explained later.

model	Model	model	Model
DTH31-10K	Standard model	DTH31-10KL_	Extended model
DTH31-15K		DTH31-15K L	
DTH31-20K		DTH31-20KL_	

The above models can be added with the <Parallel> function , and the installation and use of related functions will be explained later.

### 2-1. Unpacking and inspection

Please open the package and check whether the following items are complete. Items included in the package are as follows:

- One UPS host
- One user manual
- Monitoring software installation CD
- One RS-232 connection cable ( optional )
- One USB cable
- One parallel control connection line ( only for models that support parallel control )
- One shunt connection line ( only for models supporting parallel control )
- One battery cable ( only for 10K extended model )

**Note:** Before installation, please check the packaging contents to confirm that there is no suspected breakage or damage. If there is any damage or missing parts, do not use this product, but notify the carrier and your dealer immediately. Please keep the original packaging materials in case you need them in the future.

## 2-2.Back panel

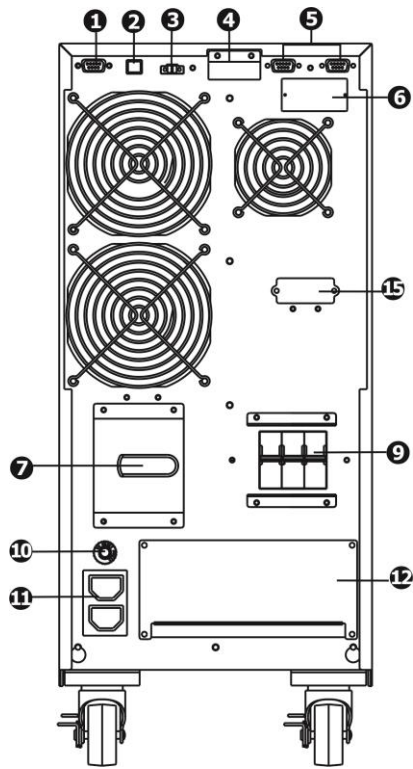

**Figure 1: 10K/10KL rear panel**

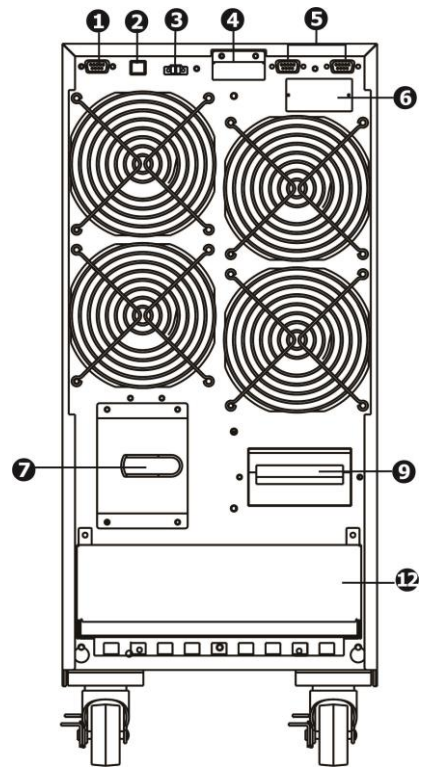

**Figure 2: 15KL/20KL back panel**

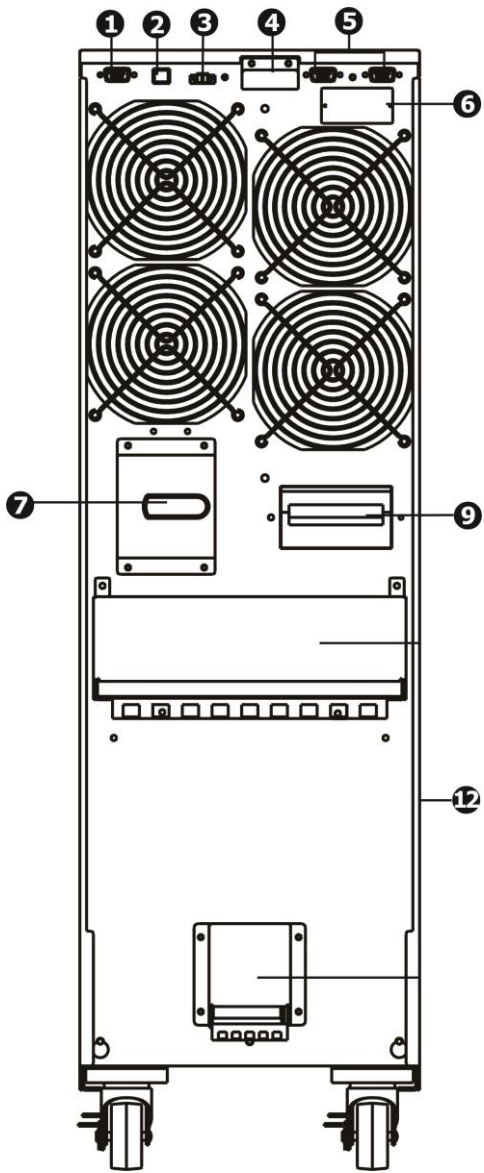

**Figure 3: 15K/20K back panel**

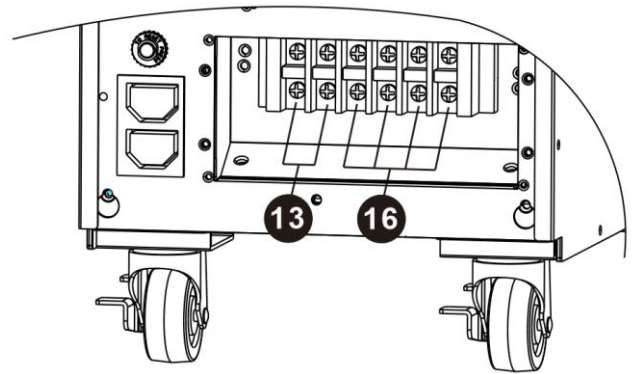

**Figure 4: 10K/10KL input/output terminal block**

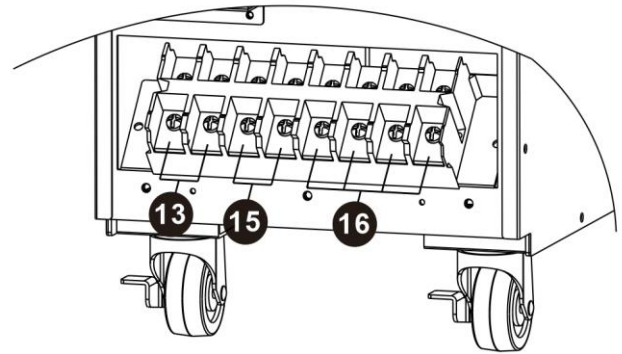

**Figure 5: 15KL/20KL input/output terminal block**

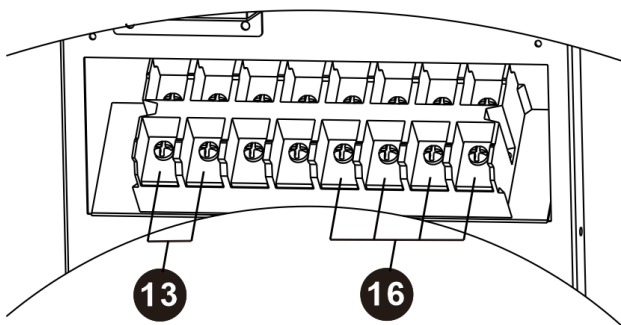

**Figure 6: 15K/20K input/output terminal block**

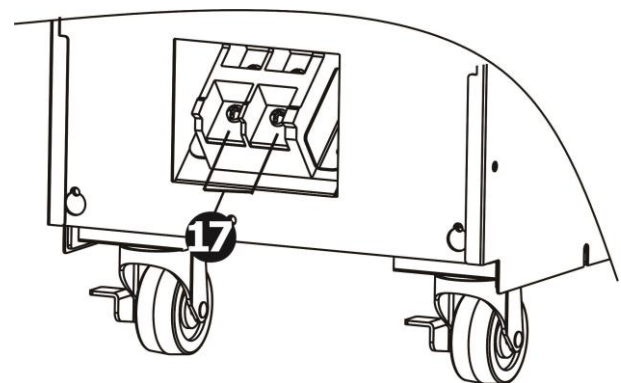

**Figure 7: 15K/20K ground terminal block**

1. RS-232 communication port
2. USB communication port
3. Emergency power off function connector (EPO connector )
4. Shunt port ( only for models supporting parallel control )
5. Parallel control port ( only for models that support parallel control )
6. smart card slot
7. Maintenance bypass switch
8. External maintenance bypass switch port
9. Mains input circuit breaker
10. Output socket circuit breaker
11. Output socket: for critical load equipment
12. Input and output terminals ( please refer to Figure 4 , 5 , 10 , 12 and Figure 14 for details )
13. Output terminals: for critical load equipment
14. Programmable output terminal: used to connect secondary load equipment
15. External battery terminal ( extension model only )
16. Mains input terminal
17. Ground terminal

### 2-3. Separate UPS installation

Installation and wiring must comply with local electrical regulations, and the following instructions must be carried out by professional electricians:

- 1) Confirm that the building's power distribution lines and circuit breakers are sufficient to support the capacity of the UPS to avoid electric shock or fire accidents.

**Note:** If the rated current of the indoor socket is less than the maximum current of the UPS , the UPS system must not be plugged into this socket; otherwise, the socket may burn out.

- 2) Before installation, turn off the main power switch in the room.
- 3) All load equipment must be powered off before being connected to the UPS system.
- 4) Prepare the wire according to the following comparison table:

model	Wiring specifications (AWG)			
	enter	output	Battery	ground
10K standard machine	8	8	/	8
10K long extension machine	8	8	8	8
15K standard machine	6	6	/	6
15K long extension machine	6	6	6	6
20K standard machine	6	6	/	6
20K long extension machine	6	6	6	6

**Note 1:** The wire used for the 10K standard machine and the extended machine must be able to

withstand currents exceeding 63A . Therefore, it is recommended to use 8AWG or higher gauge wire for both safety and efficiency.

**Note 2: The wire** used for the 15K standard machine and the extended machine must be able to withstand currents exceeding 75A . Therefore, it is recommended to use 6AWG or higher gauge wire for both safety and efficiency.

**Note 3: The wire** used for the 20K standard machine and the extended machine must be able to withstand currents exceeding 100A . Therefore, it is recommended to use 6AWG or higher gauge wire for both safety and efficiency.

**Note 4 :** The color of the wire must comply with local electrical regulations.

5) Remove the terminal block protective cover on the back panel of the UPS . Next, wire the wiring according to the terminal block diagram below: ( When wiring, please connect the ground wire first. When removing the wiring, leave the ground wire until the end !)

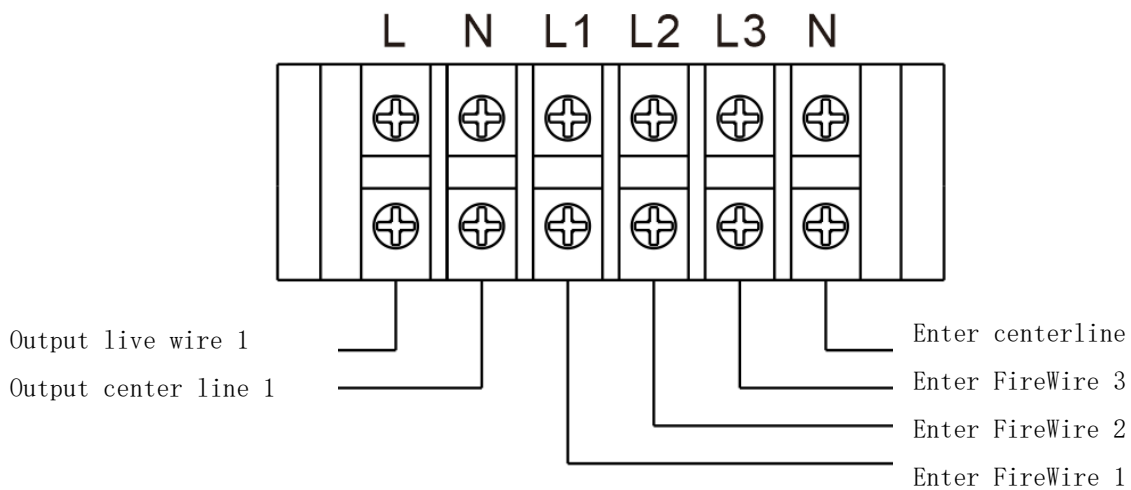

Terminal block wiring diagram 10K standard machine and extended machine

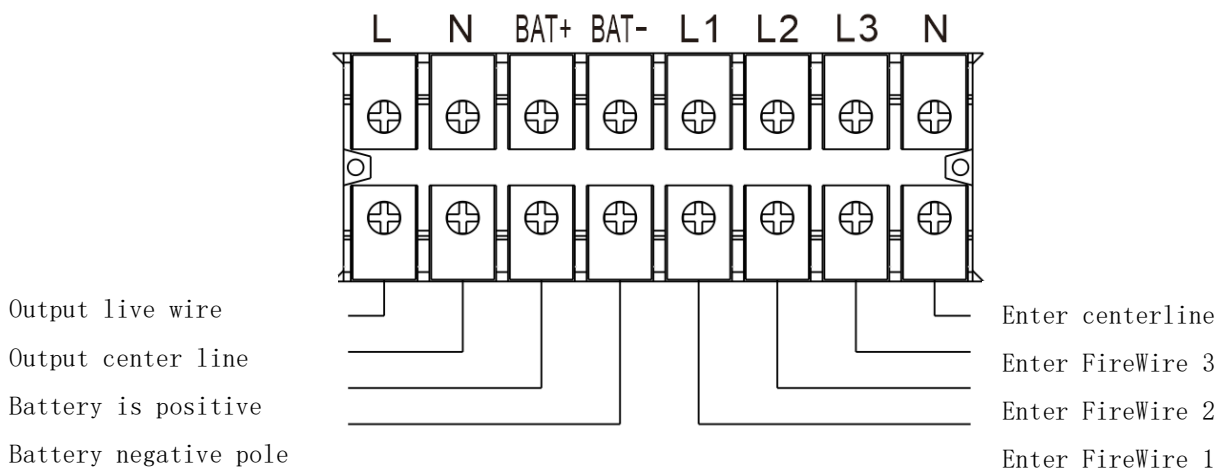

Terminal block wiring diagram 15K/20K long extension machine

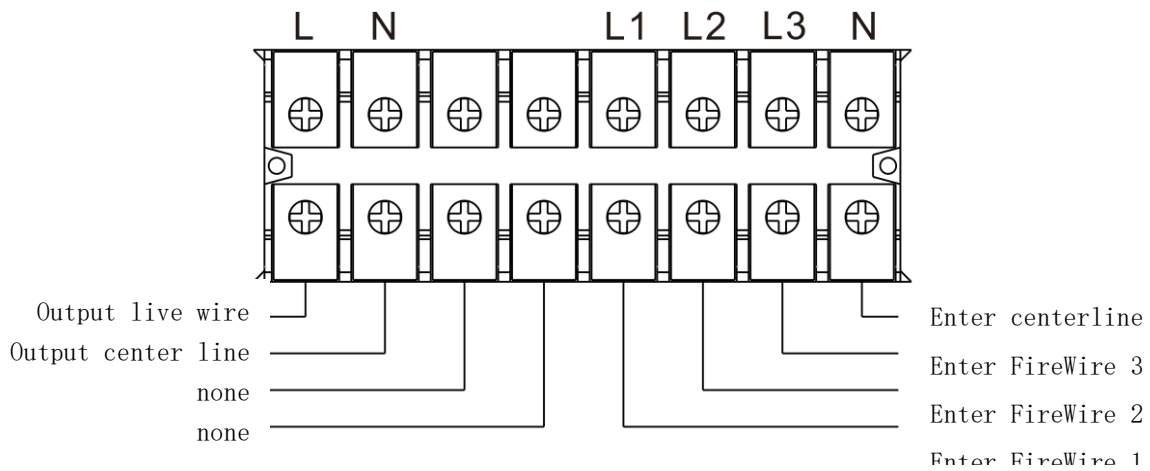

Terminal block wiring diagram 15K/20K standard machine

**Note 1 :** Make sure all wires on the terminals are locked and secure.

**Note 2 :** There are two output styles : Output terminals / sockets and programmable output terminals , please connect less important equipment and instruments to the programmable output terminals and connect important equipment and instruments to general output terminals / sockets. When the power is out, you can shorten the Program the discharge time of the output terminal to extend the discharge time of important equipment and instruments connected to general terminals / sockets.

**Note 3 :** If necessary, please install an output circuit breaker between the output terminal and the load device, and make sure that the circuit breaker has the appropriate leakage prevention function according to the specifications.

6) Reinstall the terminal block protective cover into its original position.



**warn:** ( Standard machine only )

- Make sure the UPS is shut down before installation . Make sure the UPS is turned off when wiring to avoid danger.
- Please do not modify the standard machine into a long-range machine by yourself . In particular , do not try to directly connect the battery inside the standard machine to an external battery. The battery type and voltage may be inconsistent. If you connect it by yourself, it may cause an electric shock or fire. Please Avoid with caution.



**warn:** ( Extension machine only )

- On the standard battery box, there is a DC circuit breaker to disconnect the battery kit and the UPS . However, for other external batteries, please confirm whether there is a DC circuit breaker or other protective equipment with the same function between the UPS and the external battery. If not, use caution when installing the external battery. If there is a circuit breaker, please disconnect the battery circuit breaker before installation.

**Note:** When installing a standard battery box, please set the circuit breaker of the kit to <OFF> before installation.

- Please confirm the battery voltage indicated on the back panel. If you want to change the number of batteries in the battery box, remember to modify the settings at the same time. If the wrong battery voltage is connected, the UPS may be damaged beyond repair; therefore, always confirm that the battery voltage meets UPS specifications.

- Please be sure to read the positive and negative polarity marks on the external battery terminals to correctly connect the positive and negative poles of the battery; otherwise, if the wrong polarity is connected, the UPS may be damaged beyond repair.
- Please confirm that the ground wire is wired correctly. In particular, it is necessary to check in detail and confirm that the current specifications, color, location, wiring, and conductivity reliability of the wiring meet the requirements.
- Please confirm that the mains input and output wiring are correct. In particular, it is necessary to check in detail and confirm that the current specifications, color, location, wiring, and conductivity reliability of the wiring meet the requirements. Please check and confirm that the live wire and neutral wire are connected correctly, and there is no reverse connection or short circuit.
- Before turning on the machine, make sure the circuit breaker of the battery box is turned on.
- When the circuit breaker of the external battery box is not turned on, the UPS will emit a warning sound. At this time, please turn on the external battery circuit breaker and press the "Test" button on the UPS panel to eliminate the warning sound.

## **2-4. UPS installation in parallel system**

If your UPS is used to operate alone, you can skip this section and read the next section directly.

- 1) the installation and wiring of each UPS according to the instructions in Section 2-3 ;
- 2) Connect an output circuit breaker to the output wiring of each UPS ;
- 3) Connect all the above output circuit breakers together to a main output circuit breaker, and this main output circuit breaker will be directly connected to the load equipment;
- 4) Connect the respective battery boxes to each UPS ;

**Note:** Parallel systems cannot share a battery pack to avoid irreparable damage to the system.

- 5) Carry out wiring according to the following wiring diagram:

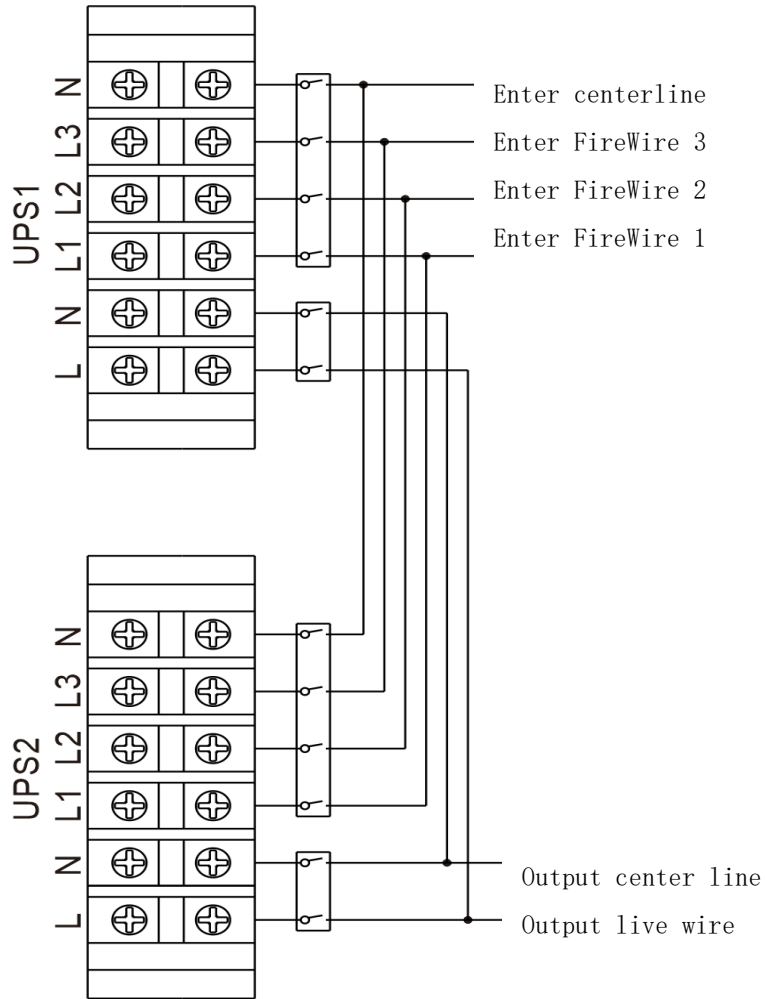

10K parallel system wiring diagram

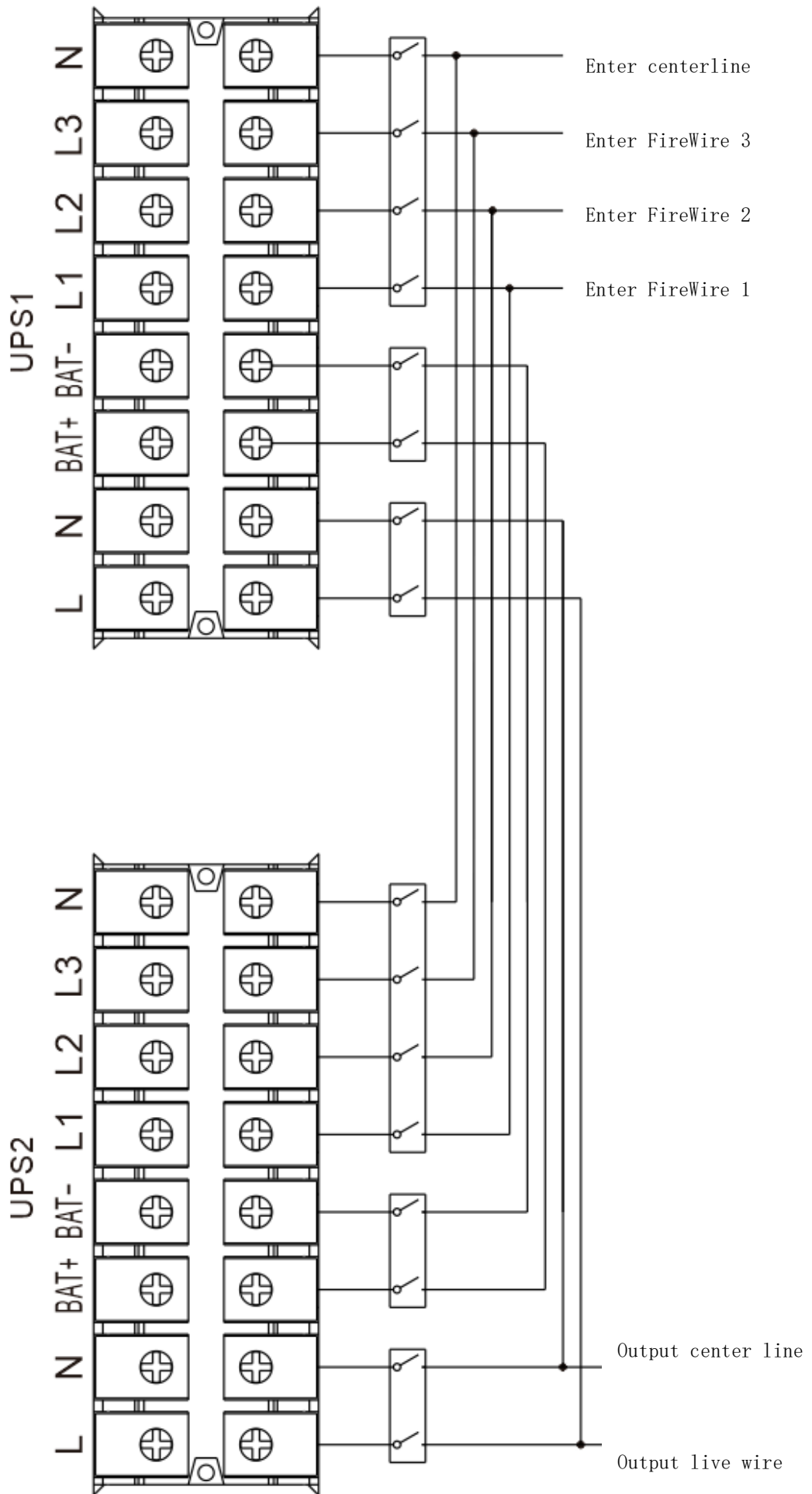

15K/20K standard machine and extended machine parallel system wiring diagram

## **2-5. Software installation**

In order to provide the most complete computer protection, please install UPS monitoring software to complete the UPS shutdown setting.

### 3. Use operations

#### 3-1. Key operation

Button	Function Description
Open / Enter key (ON/Enter)	<ul style="list-style-type: none"> <li>➤ Turn on UPS : Press and hold this button for more than 0.5 seconds, and the UPS will power on.</li> <li>➤ Enter key: When making settings on the menu screen, press this button to confirm your options.</li> </ul>
Close /ESC key (OFF/ESC)	<ul style="list-style-type: none"> <li>➤ Turn off the UPS : Press and hold this button for more than 0.5 seconds, the UPS will lose power and stop operating.</li> <li>➤ Esc key: When making settings on the menu screen, press this button to return to the previous menu.</li> </ul>
Test / up key (Test/Up)	<ul style="list-style-type: none"> <li>➤ Battery test: In AC mode or CVCF mode * , the battery can be tested by pressing and holding this button for more than 0.5 seconds.</li> <li>➤ Up key: In the menu screen, press this button to display the next option.</li> </ul>
Mute / down key (Mute/Down)	<ul style="list-style-type: none"> <li>➤ Turn off the alarm sound: Press and hold this button for more than 0.5 seconds to turn off the alarm sound. See Section 3-4-9 for details .</li> <li>➤ Down Arrow: In the menu screen, press this button to display the previous option.</li> </ul>
Test / up key + mute / down key	<ul style="list-style-type: none"> <li>➤ Press these two buttons simultaneously and hold them down for more than 1 second to open or end the setting menu.</li> </ul>

\*CVCF mode refers to constant voltage and constant frequency mode.

#### 3-2. LED indicator and LCD panel

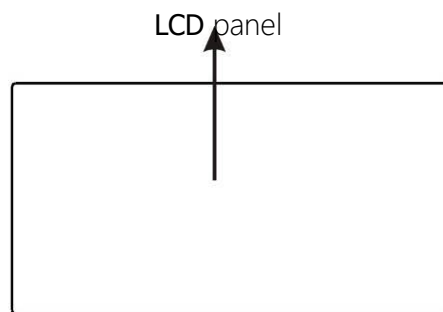

#### LED indicator light:

4 LED lights on the front panel to display the UPS operating status:







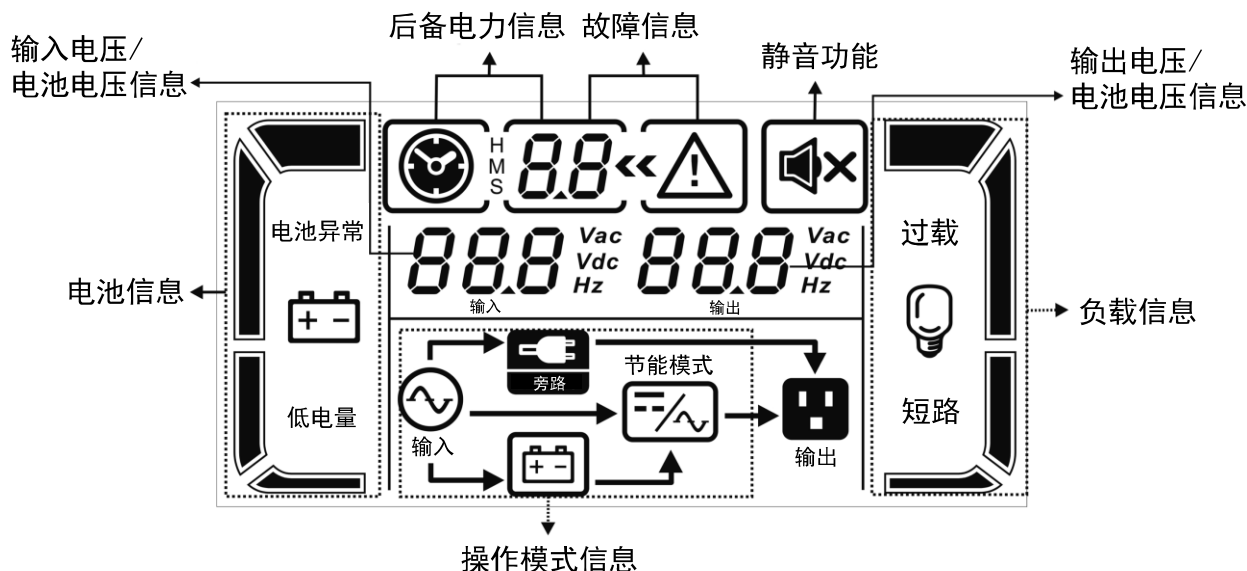









Status LED	Bypass	Line	Battery	Fault
UPS start	●	●	●	●
No output mode	○	○	○	○
Bypass mode	●	○	○	○
AC mode	○	●	○	○
battery mode	○	○	●	○
CVCF mode	○	●	○	○
battery test	●	●	●	○
ECO mode	●	●	○	○
malfunction	○	○	○	●



Note: ● means that the LED indicator light is on, and ○ Indicates that the LED indicator light is off.

## LCD panel:

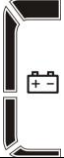

显示	功能
<b>备援时间信息</b>	
	以数字与图标显示电池放电时间。 H: 小时, M: 分钟, S: 秒钟
<b>故障讯息</b>	
	显示警告与故障发生。
	显示故障码, 详细故障讯息请参考3-9章节。
<b>静音</b>	
	显示UPS的警音功能已经停用。
<b>输出和电池的电压信息</b>	
	显示输出电压、频率或电池电压。 Vac: 输出电压; Vdc: 电池电压; Hz: 频率
<b>负载信息</b>	
	以等级来显示目前的负载量, 分成 0-25%、26-50%、51-75%、和 76-100%。
<b>过载</b>	显示已过载。
<b>短路</b>	显示负载端或 UPS 输出端发生短路。
<b>可程序插座信息</b>	
	显示可程序插座正在运作中。
<b>其他运作信息</b>	
	显示 UPS 系统连上主电源。
	显示电池正在供电中。
	显示已进入旁路功能模式。
	显示已进入 ECO 模式。
	显示变频电路运作中。

 输出	显示目前输出插座输出中。
<b>电池信息</b>	
	以等级来显示目前的电池电量，分成 0-25%、26-50%、51-75%、和 76-100%。
电池异常	显示电池接线未接好。
低电量	显示电池电量及电压已偏低。
<b>输入和电池的电压信息</b>	
 输入 12	显示输入电压或频率，或是电池电压。 Vac: 输入电压; Vdc: 电池电压; Hz: 输入频率
<b>show</b>	<b>Function</b>
<b>Backup time information</b>	
	Displays battery discharge time with numbers and icons. H: hour, M: minute, S: second
Fault message	
	Display warnings and <b>fault</b> occurrences.
	A fault code is displayed. For detailed fault information, please refer to Chapter 3-9 .
<b>mute</b>	
	Indicates that the UPS alarm sound function has been disabled.
<b>Output and battery voltage information</b>	
 输出	Displays output voltage, frequency or battery voltage. Vac: output voltage; Vdc: battery voltage; Hz: frequency
<b>load information</b>	
	Display the current load in levels, Divided into 0-25% , 26-50% , 51-75% , and 76-100% .
过载	Display is overloaded.
短路	Displays a short circuit at the load end or UPS output end.
<b>Programmable socket information</b>	
	Indicates that the programmable socket is operating.
<b>Other operational information</b>	
 输入	Shows that the UPS system is connected to the main power supply.
	Shows that the battery is supplying power.
 旁路	It shows that the bypass function mode has been entered.
	It shows that it has entered ECO mode.
	Indicates that the frequency conversion circuit is operating.
 输出	Displays the current output of the output socket.
<b>battery information</b>	

	Displays the current battery level in levels, Divided into 0-25% , 26-50% , 51-75% , and 76-100% .
电池异常	It shows that the battery wiring is not connected properly.
低电量	It shows that the battery power and voltage are low.
<b>Input and battery voltage information</b>	
	Displays input voltage or frequency, or battery voltage. Vac: input voltage; Vdc: battery voltage; Hz: input frequency

### 3-3.Alarm sound

illustrate	Alarm status	mute
<b>UPS status</b>		
Bypass mode	Beeps every 2 minutes	Can
battery mode	Beeps every 4 seconds	
Failure mode	Continuously beeping	
warning		
overload	Two beeps per second	no
Other alert status	One sound per second	
Fault ( detailed fault event display, please refer to 3-9 fault code )		
All fault conditions	Continuously beeping	Can

### 3-4. Stand-alone operation

#### 1. Turn on the UPS power supply (AC mode ) when the mains power is connected

- 1) After correctly connecting the power supply, first switch the circuit breaker of the battery box to the <ON> position ( this step is only applicable to the extended model ) , and then switch the input circuit breaker to <ON> . As a result, the cooling fan should start to rotate and the UPS will start to initialize. After a few seconds, the UPS will supply power to the load in bypass mode, that is, the UPS is in bypass mode to supply power.

**Note:** When the UPS is in bypass mode and the above input circuit breaker is turned on, the output voltage of the UPS comes directly from the utility power. In other words, in bypass mode, the UPS does not provide any protection to the load. In order to protect your equipment, you need to turn on the UPS ; please refer to the following steps for related turning on operations.

- 2) Press and hold the <ON> button for 0.5 seconds to turn on the UPS , and you will hear a beep at this time.
- 3) After a few seconds, the UPS will enter AC mode. At this time, if the mains power is abnormal, the UPS will directly enter battery mode to avoid interruption of power supply to the load.

**Note:** In battery mode , the UPS will automatically shut down after draining the battery power. Then, after the utility power is restored, the UPS will automatically restart and enter AC mode.

#### 2. Turn on the UPS ( battery mode ) when there is no mains power

- 1) Please confirm that the circuit breaker of the battery box is set to the <ON> position ( only for extended extension models ) .
- 2) Press and hold the <ON> button for 0.5 seconds. The UPS will start to initialize and then enter the no-output mode. At this time, after pressing the <ON> button for 0.5 seconds, the UPS can be turned on , and you will hear a sound. beep.

3) After a few seconds, the UPS will turn on and enter battery mode.

### **3. Connect the load to the UPS**

After the UPS is turned on, you can connect your equipment to the UPS .

- 1) Turn on the UPS first , and then turn on your devices one by one; at this time, the LCD panel will display the current load level.
- 2) If you need to connect inductive loads such as printers, you need to first calculate the current when these loads are operating to confirm whether the UPS capacity is sufficient to support such loads, because generally the power required by such loads will exceed the UPS the extent to which it can be supported.
- 3) When the UPS is overloaded, the alarm will sound twice per second.
- 4) When the UPS is overloaded, please remove part of the load immediately. It is recommended that the total load connected to the UPS be limited to less than 80% of the UPS's normal supported specifications to avoid overload and ensure system safety.
- 5) In AC mode, if the number of times the UPS is overloaded exceeds the number allowed by the specification, the UPS will automatically transfer to bypass mode. After the overloaded equipment is removed, the UPS will return to AC mode. On the other hand, if the number of overloads exceeds the specification and occurs in battery mode, the UPS will enter a fault state. In this case, if the bypass function is set to enabled, the UPS will supply power to the load in bypass mode. However, if the bypass function is not configured to be enabled or the input power exceeds the support range of the bypass function, the UPS will directly stop supplying power.

### **4. Battery charging**

- 1) Except in battery mode or battery test, the charger will automatically start charging the battery as soon as the UPS is connected to the power supply.
- 2) It is recommended to charge for at least 10 hours before turning on the UPS . Otherwise, the battery backup time may be shorter than originally expected due to insufficient charging .
- 3) Please confirm that the number of batteries set on the control board ( please refer to Section 3-4-12 ) matches the actual number of connected batteries.

### **5. Battery mode operation**

- 1) When the UPS is in battery mode, the way and interval of the alarm sound will be different according to the remaining power of the battery: when the remaining power of the battery is higher than 25% , a beep will sound every 4 seconds; When the battery voltage drops to the warning level, the alarm interval will be shortened to one sound per second to warn the user that the battery power is low and the UPS will automatically shut down. In the latter case, the user can temporarily disable the automatic shutdown alarm by turning off some secondary equipment and thereby extend the battery backup time ( if the programmable output function has been enabled, the UPS will automatically shut down the programmable output function at this time. power supply on the output terminals ) . If there are no other devices that can be shut down at the time to extend the battery life, you must immediately start shutting down all devices that need to be protected or store important data to avoid sudden power outages causing device failure or data loss.
- 2) In battery mode, if the alarm sound is annoying, you can turn off the alarm sound by pressing the <Mute> button.
- 3) The power backup time of extended models depends on the capacity of the external battery.
- 4) Battery backup time will vary depending on the ambient temperature and type of load equipment.
- 5) When the power backup time is set to 16.5 hours ( the default value set by the LCD panel ) , after the UPS is powered by the battery for 16.5 hours, it will automatically shut down to protect the battery. This battery discharge protection function can be enabled or disabled via the LCD panel ( please refer to Section B of < Section 3-7 LCD Settings > for details )

## 6. Battery test

- 1) When the UPS is in AC mode /CVCF mode /ECO mode, if you need to check the battery status, you can press the <Test> button to let the UPS perform battery self-test.
- 2) Users can also use monitoring software to set the execution method of battery self-test.

## 7. Turn off the UPS in AC mode powered by mains power

- 1) Press the <OFF> button of the UPS for 0.5 seconds to turn off the UPS inverter, and you will hear a beep at this time. After shutdown, the UPS will enter bypass mode.

**Note 1 :** If the UPS has been set to enable bypass output, even if you turn off the UPS ( inverter ) , the UPS will still output voltage to the output socket or terminal by bypassing the mains power.

**Note 2 :** After turning off the UPS , please remember that the UPS supplies power in bypass mode; in other words, once the mains power fails, the equipment connected to the UPS may be powered off immediately.

- 2) In bypass mode, the UPS still has voltage at the output. If you need to turn off the output, please turn off the input circuit breaker. After a few seconds, the LCD panel will turn off and the UPS will shut down completely with no output.

## 8. Shut down the UPS in battery mode without mains power

- 1) Press the <OFF> button of the UPS for 0.5 seconds to turn off the UPS , and you will hear a beep at this time.
- 2) The UPS will turn off all outputs, and the LCD panel will not display anything.

## 9. Turn off the alarm sound

- 1) If you want to turn off the alarm sound, please press the <Mute> button for at least 0.5 buttons. After turning off the alarm sound, if you press this button again, the alarm sound function will be restored.
- 2) Some alarm sounds cannot be turned off until the problem is eliminated. See Section 3-3 for details .

## 10. Operation under warning status

- 1) When the <Fault> LED indicator light flashes and the alarm beeps once every second, it means that some problems have occurred in the operation of the UPS . Users can find the fault code on the LCD panel and solve the problem according to the troubleshooting methods detailed in Chapter 4 .
- 2) Some alarm sounds cannot be turned off until the fault is eliminated. See Section 3-3 for details .

## 11. Operation in failure mode

- 1) When the <Fault> LED indicator lights up and the alarm sound continues to sound, it means that a fatal fault has occurred in the UPS that is enough to interrupt operation. Users can find the fault code on the LCD panel and solve the problem according to the troubleshooting methods detailed in Chapter 4 .
- 2) When this type of fault occurs, please immediately check the load, wiring, ventilation, mains, battery and other parts. Never attempt to restart the UPS until the problem is resolved . If the problem cannot be solved, please contact your dealer or service personnel immediately.
- 3) If the situation is urgent, please immediately disconnect the mains power, external battery, and output to avoid further danger.

## 12. Operation to change the number of batteries

- 1) This operation can only be performed by professional and technical personnel.
- 2) Turn off the UPS first . If the load cannot be disconnected, first remove the protective cover of the maintenance bypass switch located on the rear panel and switch the switch to the <BPS> position.

- 3) Disconnect the input circuit breaker and disconnect the battery circuit breaker ( only for long-term extension models ) .
- 4) Unplug the battery cable and take off the casing of the machine. If you are using a standard model, you also need to disconnect the battery cable and set the number of batteries by adjusting the jumper (JS3) on the control board ( see below) table ) .

Number of batteries connected in series	JS3			
	pin1 and pin2	pin3 and pin4	Pin5 and pin6	pin7 and pin8
18	1	0	0	X
19	0	1	0	X
20	0	0	1	X

Note :  
1

represents short jumper pin ; 0 represents no jumper pin ; x represents that this jumper pin is used for other functions.

- 5) After carefully setting the number of batteries, rewire the battery connections and replace the machine casing. For long-term use, the battery circuit breaker must be turned on.
- 6) Set the input circuit breaker to open, and the UPS will enter bypass mode. If the UPS is in maintenance bypass mode, please set the maintenance switch to <UPS> before turning on the UPS .

## 3-5 . Parallel operation

### 1. Connection of parallel systems

UPS used are parallel models and have the same settings.

- 1) each UPS in sequence and enter the mains mode ( please follow Section 3-4(1) ) . Then, measure the output voltage of each UPS to confirm that the difference between the actual output voltage and the set output voltage is less than 1.5 V. If the voltage difference between the two is greater than 1.5V , the inverter voltage needs to be recalibrated. Please refer to the 15th setting in Chapter 3-7 LCD Settings . If the voltage difference after calibration is still greater than 1.5V , please contact your local dealer.
- 2) Through the calibrated output voltage in the LCD settings ( please refer to the 16th setting in the LCD settings in Chapter 3-7 ) , confirm that the difference between the actual output and the output voltage detected by the UPS is less than 1V .
- 3) Turn off each UPS ( please follow Chapter 3-4(1) ) , and then wire in sequence according to Chapter 2-4 .
- 4) Remove the protective cover from the parallel shunt port of the UPS , connect the parallel lines and shunt lines to the UPS one by one, tighten these connections with screws, and then lock the protective cover back into place.
- 5) Turn on the parallel system in mains mode
  - a. After opening the input circuit breakers of all UPSs in the parallel system , turn on the UPSs one by one . When all UPS enters bypass mode, use a multimeter to measure the L1 and L2 output voltages of each UPS to confirm whether the voltage difference between the two is less than 1V . If the voltage difference is less than 1V , it means that all wiring is correct. Otherwise, re-confirm Are the connection lines correct?
  - b. the output circuit breaker of each UPS .
  - c. Turn on each UPS in sequence . After a while, all UPS will enter the mains mode in sequence, and the parallel system startup is completed.
- 6) Turn on parallel system in battery mode
  - a. Turn on the output circuit breaker of each UPS . If it is a long-term extension model, you need to turn on the battery circuit breaker.  
Note : Each extended model in the parallel system needs to be connected to a battery box independently, and a battery box must not be shared.
  - b. First turn on a UPS , and then the UPS will enter battery mode.
  - c. Turn on another UPS . After a few minutes, this UPS will enter battery mode and join the parallel system.
  - d. If there is a third machine, please follow the above steps to start it, and then the parallel system startup is completed.

If you need more detailed step-by-step instructions, please contact your local dealer.

### 2. Add a UPS to the parallel system

- 1) When the parallel system is operating, the UPS cannot be loaded . You must first disconnect all loads and shut down the entire system.
- 2) Please confirm that all UPS are parallel models, and then perform wiring according to Section 2-4 .
- 3) Install the new parallel system according to the previous section.

### 3. Remove one UPS from the parallel system

There are two methods :

#### **Method one :**

- 1) "OFF" button on the UPS to be removed twice for at least 0.5 seconds each time. The UPS will enter bypass mode or no output mode.
- 2) this UPS , and then open the input circuit breaker of the UPS .
- 3) If it is a long-term extension model, you need to turn off the battery circuit breaker. After the UPS is shut down, remove the current equalization wire and parallel wire of the UPS , and remove the UPS to be removed .

#### **Method two :**

- 1) If you cannot enter bypass mode normally, you must shut down the system before removing the UPS . You need to disconnect the load before shutting down the system.
- 2) After confirming that the bypass settings of each UPS have taken effect, shut down the operating system. All UPS will enter bypass mode. Here, remove all maintenance bypass protective covers and switch the maintenance switch from <UPS> to <BPS> . Disconnect the input circuit breakers and battery circuit breakers of all UPS in parallel systems .
- 3) Disconnect the output circuit breaker, remove the current equalizing wire and parallel wire of the UPS to be removed , and then remove the UPS .
- 4) Turn on the input circuit breaker of the remaining UPS to put the system into bypass mode. After switching the maintenance switch from <BPS> to <UPS> , reinstall the maintenance bypass protective cover .
- 5) Turn on the remaining UPS according to the previous chapter to complete the UPS removal of the parallel system.



**warn:** ( Parallel system only )

- When turning on the parallel system and starting the inverter, be sure to confirm that the maintenance switches of all UPS are set to the same position.
- When the parallel system is turned on and powered by the inverter, do not operate the

maintenance switch of any UPS .

### 3-6 . Abbreviations on LCD display

abbreviation	Display content	significance
ENA	<i>ENA</i>	Enable _
DIS	<i>DIS</i>	Disable _
ATO	<i>ATO</i>	Auto _
BAT	<i>BAT</i>	Battery _
NCF	<i>NCF</i>	Normal mode ( Non - CVCF mode ) _
CF	<i>CF</i>	CVCF mode
SUB	<i>SUB</i>	Subtract _

ADD	<i>Add</i>	Add _
ON	<i>ON</i>	On _
OFF	<i>OFF</i>	Off (Off)
FBD	<i>Fbd</i>	Not allowed
OPN	<i>OPN</i>	Allow _
RES	<i>RES</i>	Reserved _
NL	<i>NL</i>	Neutral line loss
CHE	<i>CHE</i>	Check
OP.V	<i>OPV</i>	Output voltage
PAR	<i>PAR</i>	Parallel connection. 001 represents the first
L1	<i>L1</i>	first phase line
AN	<i>AN</i>	
L2	<i>L2</i>	Second phase line
BN	<i>BN</i>	
L3	<i>L3</i>	Third phase line
EN	<i>EN</i>	

### 3-7 . LCD settings \_

There are three parameters here to configure your UPS . Please refer to the picture below.

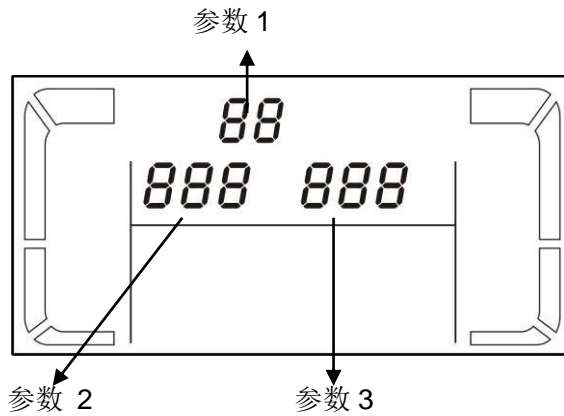

Parameter 1: This is the program option number. For detailed setting procedures, please refer to the table below.

Parameter 2 and parameter 3 are used to set options and values in each program.

Note: Please press the "Up" or "Down" key to select an option or change the parameter value.

#### 3-7-1. 10~20K

##### List of setting procedures represented by parameter 1 :

serial number	illustrate	bypass / no output	AC	ECO	CVCF	Battery	Battery test
01	The output voltage	Y*					
02	Output frequency	Y					
03	Allowable voltage range of bypass	Y					
04	Allowable frequency range of bypass	Y					
05	ECO mode activation / deactivation	Y					
06	ECO mode	Y					
07	Allowable frequency range setting in ECO mode	Y					
08	Bypass mode setting	Y	Y				
09	Battery maximum power time setting	Y	Y	Y	Y	Y	Y
10	Programmable output settings	Y	Y	Y	Y	Y	Y
11	Programmable output shutdown time	Y	Y	Y	Y	Y	Y
12	N wire connection check warning	Y	Y	Y	Y	Y	Y
13	Battery voltage calibration	Y	Y	Y	Y	Y	Y
14	Charging voltage adjustment	Y	Y	Y	Y	Y	Y
15	Inverter voltage adjustment		Y		Y	Y	
16	Output voltage calibration		Y		Y	Y	
17	Input phase adaptation function enable / disable **	Y					

\*Y indicates that the program can be set in the corresponding mode.

\*\* This function allows the UPS input phase to be more flexible. When this function is enabled, the UPS can

accept several input phase differences so that the UPS operates like a single-phase UPS . If this function is disabled, the UPS can only operate on L1, L2, and L3 operate in the standard input phase sequence, please refer to 17 in the LCD program settings .

Note : All setting changes are saved only when the UPS has a battery connected and is shut down normally.  
( Normal UPS shutdown refers to opening the input circuit breaker in bypass or no output mode )

● **01: Output voltage**

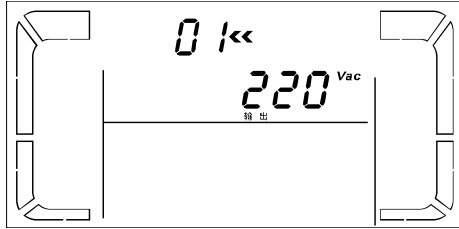
Panel display	set up
 <p>The panel display shows '01&lt;&lt;' at the top, '220 Vac' in the middle, and '输出' (Output) at the bottom.</p>	<p><b>Parameter 3 : Output voltage</b>            You can select the following output voltage with parameter 3 :</p> <ul style="list-style-type: none"> <li><b>208:</b> The default output voltage is 208Vac</li> <li><b>220:</b> Default output voltage is 220Vac</li> <li><b>230:</b> Default output voltage is 230Vac</li> <li><b>240:</b> The default output voltage is 240Vac</li> </ul>

● **02: Output frequency**

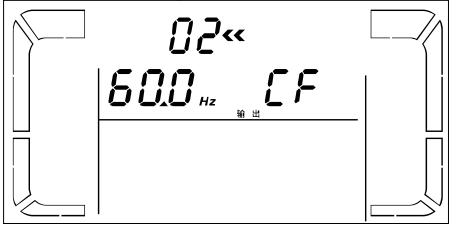
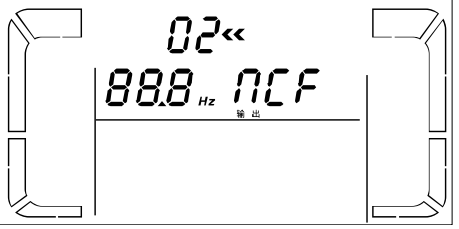
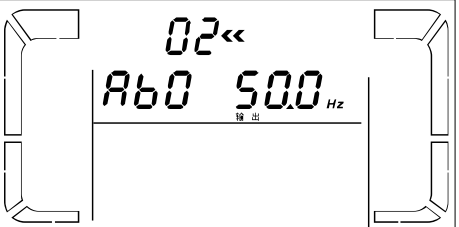
Panel display	set up
<p><b>60 Hz, CVCF mode</b></p>  <p>The panel display shows '02&lt;&lt;' at the top, '60.0 Hz' and 'CF' in the middle, and '输出' (Output) at the bottom.</p> <p><b>50 Hz, normal mode</b></p>  <p>The panel display shows '02&lt;&lt;' at the top, '88.8 Hz' and 'NCF' in the middle, and '输出' (Output) at the bottom.</p> <p><b>ATO</b></p>  <p>The panel display shows '02&lt;&lt;' at the top, 'A60' and '50.0 Hz' in the middle, and '输出' (Output) at the bottom.</p>	<p><b>Parameter 2 : Output frequency</b>            Used to set the output frequency. Here, parameter 2 has the following three options:</p> <ul style="list-style-type: none"> <li><b>50.0Hz:</b> The output frequency is set to 50.0Hz.</li> <li><b>60.0Hz:</b> The output frequency is set to 60.0Hz.</li> <li><b>ATO:</b> If this option is selected, the output frequency will depend on the mains frequency of the last normal UPS operation. If the mains frequency is between 46Hz and 54Hz, the output frequency will be set to 50.0Hz; if it is between 56Hz and 64Hz, the output frequency will be set to 60.0Hz. ATO is the default value.</li> </ul> <p><b>Parameter 3 : Frequency mode</b>            Set the output frequency of CVCF mode and non- CVCF mode. Here, parameter 3 has the following 2 options:</p> <ul style="list-style-type: none"> <li><b>CF:</b> Set the UPS to CVCF mode. If this option is selected, the output frequency will be fixed at 50Hz or 60Hz according to the setting of parameter 2. The allowed input frequency range is 46Hz to 64Hz.</li> <li><b>NCF:</b> Set the UPS to normal mode ( non- CVCF mode ). If this option is selected, the output frequency will be 50Hz when the input frequency falls within the range of 46~54 Hz, or 60Hz when the input frequency falls within the range of 56~64 Hz, according to the setting of parameter 2. If it is set to 50 Hz according to parameter 2, when the input frequency is not within the range of 46~54 Hz, the UPS will enter battery mode; if it is set to 50 Hz according to parameter 2, when the input frequency is not within the range of 56~64 Hz When within range, the UPS will enter battery mode.</li> </ul> <p>* If parameter 2 is set to ATO, parameter 3 will display the current frequency.</p>

● **03: Allowable voltage range of bypass**

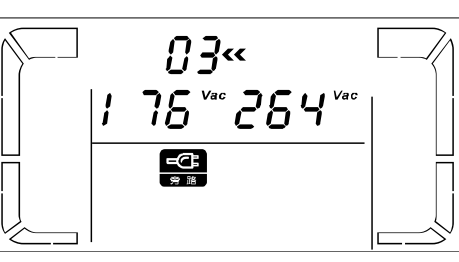
Panel display	set up
 <p>The panel display shows '03&lt;&lt;' at the top, '176 Vac' and '264 Vac' in the middle, and a bypass mode icon at the bottom.</p>	<p><b>Parameter 2 :</b> Set the minimum voltage value allowed in bypass mode. The setting range is 110V to 209V, and the default value is 110V.</p> <p><b>Parameter 3 :</b> Set the maximum voltage value allowed in bypass mode. The setting range is 231V to 276V, and the default value is 264V.</p>

● **04: Allowable frequency range in bypass mode**

Panel display	set up
---------------	--------

	<p><b>Parameter 2 :</b> Set the minimum allowable frequency in bypass mode.  50 Hz system: The setting range is from 46.0Hz to 49.0Hz .  60 Hz system: The setting range is from 56.0Hz to 59.0Hz .  The default value is 46.0Hz/56.0Hz .</p> <p><b>Parameter 3 :</b> Set the maximum allowable frequency in bypass mode.  50 Hz : The setting range is from 51.0Hz to 54.0 Hz .  60 Hz : The setting range is from 61.0Hz to 64.0Hz .  The default value is 54.0Hz/64.0Hz .</p>
---	--

● **05: ECO mode activation / deactivation**

<p><b>Panel display</b></p>	<p><b>set up</b></p>
	<p><b>Parameter 3 :</b> Enable or disable the ECO function. Here, you have the following 2 options:  <b>DIS:</b> Disable ECO function.  <b>EN:</b> Enable ECO function.  Even if the ECO function is disabled, You can still set the allowable voltage range and allowable frequency range in ECO mode; however, these range settings will not take effect until the ECO function is enabled.</p>

● **06: Allowable voltage range in ECO mode**

<p><b>Panel display</b></p>	<p><b>set up</b></p>
	<p><b>Parameter 2 : Minimum allowable voltage in ECO mode.</b>  The setting range is -5% to -10% of the rated voltage .</p> <p><b>Parameter 3 :</b> Maximum allowable voltage in ECO mode. The setting range is +5% to +10% of the rated voltage .</p>

● **07: Allowable frequency range of ECO mode**

<p><b>Panel display</b></p>	<p><b>set up</b></p>
	<p><b>Parameter 2 :</b> Set the minimum allowable frequency of ECO mode.  50 Hz system: The setting range is from 46.0Hz to 48.0Hz .  60 Hz system: The setting range is from 56.0Hz to 58.0Hz .  The default value is 48.0Hz/58.0Hz .</p> <p><b>Parameter 3 :</b> Set the maximum allowable frequency of ECO mode.  50 Hz: The setting range is from 52.0Hz to 54.0 Hz .  60 Hz: The setting range is from 62.0Hz to 64.0Hz .  The default value is 52.0Hz/62.0Hz .</p>

● **08: Bypass mode setting**

<p><b>Panel display</b></p>	<p><b>set up</b></p>
	<p><b>Parameter 2 :</b>  <b>OPN :</b> Allow entering bypass mode. When this option is selected, the UPS will determine how to perform bypass mode based on the bypass function enable / disable settings.  <b>FBD :</b> Not allowed to enter bypass mode. When this option is selected, the UPS will not enter bypass mode under any circumstances.</p> <p><b>Parameter 3 :</b>  <b>ENA :</b> Bypass function enabled. When this option is selected, bypass mode will be enabled.  <b>DIS :</b> Disable bypass function. When this option is selected, the UPS will be allowed to enter bypass mode automatically, but manual bypass mode will not be allowed. Manual bypass mode refers to the operation of manually putting the UPS into bypass</p>

mode, such as pressing the <OFF> button in AC mode and trying to put the UPS into bypass mode.

● **09: Battery maximum power supply time setting**

<b>Panel display</b>	<b>set up</b>
 The image shows a digital display panel with a yellow border. At the top left, there is a circular icon with a lightning bolt and the letter 'M'. To its right, the text '09<<' is displayed. Below this, the number '990' is shown in a larger font. At the bottom center, there is a battery icon.	<p><b>Parameter 3 :</b> <b>000~999:</b> Set the maximum battery power supply time, the setting range is from 0 minutes to 999 minutes. When the power supply time has expired, the UPS will automatically shut down to protect the battery from reaching a low voltage position. The default value is 990 minutes. <b>DIS:</b> Disable the battery discharge protection function and the power supply time will depend on the battery power.</p>

● **10: Programmable output setting ( horizontal models do not support this setting )**

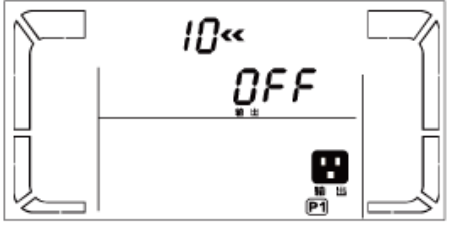
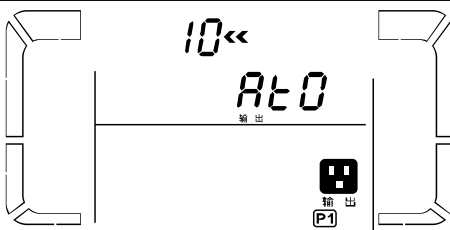
Panel display	set up
	<p><b>Parameter 3 :</b> Set the programmable output terminal. Here, there are 3 options:</p> <p><b>ON:</b> The programmable socket can be manually switched to normally open.</p> <p><b>OFF:</b> Programmable output manual mode can be switched to off. However, once the UPS restarts, this setting will automatically reset to &lt;ATO&gt; .</p>
	<p><b>ATO:</b> The programmable output will automatically switch on and off according to battery or load conditions. When the battery voltage is lower than the set value, or the shutdown time has expired, The programmable output is automatically disconnected. After the mains power is restored, the output will automatically resume power supply. If an overload situation occurs , the programmable output will also automatically disconnect, and if the overload condition occurs 3 times, the programmable output will remain closed until manually set to open.</p>

● **11: Programmable output shutdown time point ( horizontal models do not support this setting )**

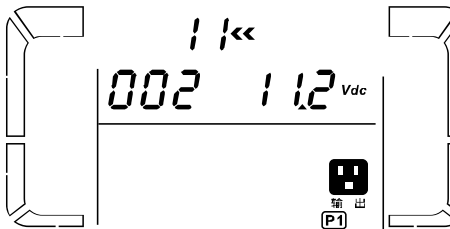
Panel display	set up
	<p><b>Parameter 2 : 001</b> Sets the closing time of the programmable output.</p> <p><b>Parameter 3 : shutdown time, unit is minutes.</b> The setting range is from 0 to 300 . When the switch-off time expires, the programmable output switches off the power supply. The default value is 30 minutes.</p>
	<p><b>Parameter 2 : 002</b> Sets the shutdown voltage of the programmable output.</p> <p><b>Parameter 3 : Turn off voltage, unit is V.</b> The setting range is from 11.2 to 13.6 . If the battery voltage falls below the value set here, the programmable output stops supplying power. The default value is 11.2V .</p>

● **12: N line connection check warning**

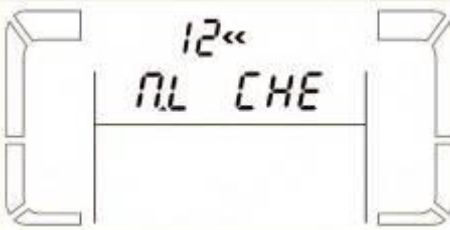
Panel display	set up
	<p><b>NL:</b> Display <b>N line connection check function</b></p> <p><b>Parameter 3:</b></p> <p><b>DIS:</b> If the N- line connection check function is disabled , the UPS will not detect whether the N -line is connected or not.</p> <p><b>ATO:</b> When this item is selected, the UPS will automatically detect whether the N line is connected. When it detects that the N line at the input terminal is not connected, an alarm sound will be generated. If the UPS is powered on, it will enter the battery discharge mode. When the N line is not connected, When detected again, the alarm sound will be automatically muted and the UPS will automatically return to normal operation.</p> <p><b>CHE:</b> When this item is selected, the UPS will automatically detect whether the N line is connected. When it detects that the N line at the input terminal is not connected, an alarm sound will be generated. If the UPS is powered on, it will enter the battery discharge mode. When the N line is not connected, When detected again, the alarm sound <b>will not be</b> automatically muted, and the UPS will <b>not</b> automatically return to normal operation.</p>

	<p>At this time, if you want to cancel the alarm sound and return the UPS to normal operation, first enter this menu, press the "Enter" key to make "CHE" flash, and then press the "Enter" key again to start the N line detection action. If the N line has been detected at this time, the alarm sound will be muted. The UPS will also switch to normal operation. If the N line has not been detected yet, the UPS will still generate the alarm sound and maintain it at the last setting. state until the next manual detection action is executed. CHE is the default value.</p>
--	--

● **13: Battery voltage calibration**

Panel display	set up
	<p><b>Parameter 2 :</b> Select &lt;Add&gt; _ or &lt;Sub&gt; <b>to</b> calibrate battery voltage.</p> <p><b>Parameter 3 :</b> The voltage range is from 0V to 9.9V , and the default value is 0V .</p>

● **14: Charger voltage calibration**

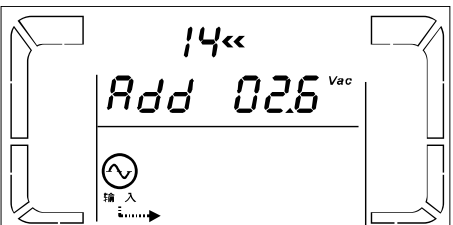
Panel display	set up
	<p><b>Parameter 2 :</b> Select &lt;Add&gt; _ or &lt;Sub&gt; <b>to</b> calibrate the charger voltage.</p> <p><b>Parameter 3 :</b> The voltage range is from 0V to 9.9V , and the default value is 0V .</p> <p><b>Note:</b></p> <ul style="list-style-type: none"> <li>* Before performing voltage calibration, be sure to disconnect all batteries to measure the correct charging voltage.</li> <li>* We strongly recommend that you leave the default value (0V) unchanged. If you need to change it, be sure to meet the battery specifications.</li> </ul>

● **15: Inverter voltage adjustment**

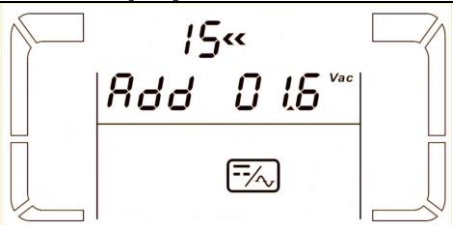
Panel display	set up
	<p><b>Parameter 2 :</b> Select &lt;Add&gt; _ Or &lt;Sub&gt; <b>to</b> set the inverter voltage adjustment method .</p> <p><b>Parameter 3 :</b> The voltage range is from 0V to 9.9V , and the default value is 0V .</p>

● **16: Output voltage calibration**

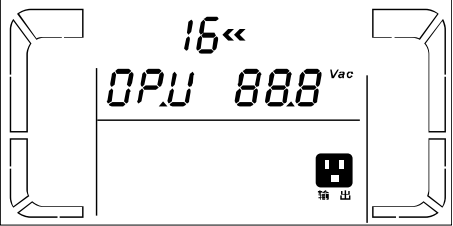
Panel display	set up
	<p><b>Parameter 2 :</b> Always display <b>OP.V</b> represents the output voltage .</p> <p><b>Parameter 3 :</b> Displays the internal calibration value of the output voltage . The calibrated value can be provided through the " <b>Up</b> " or " <b>Down</b> " <b>key</b> based on the data detected by the external voltage detection instrument . The calibrated value can be obtained after pressing " Enter" key will take effect directly and immediately, and the calibration value range needs to be within +/-9V , and this function is usually applied to parallel connection.</p>

● **17: Input phase adaptation enable / disable**

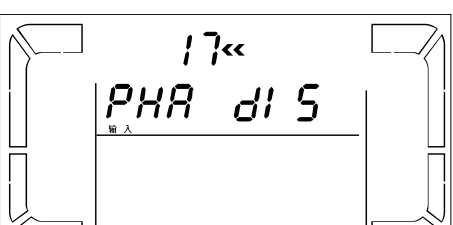
Panel display	set up
	<p><b>Parameter 2 :</b> Always displays <b>PH.A</b>, which represents the input phase adaptive function . .</p> <p><b>Parameter 3 :</b> Enable or disable this feature selection. You can choose :</p> <p><b>DIS:</b> Disable the phase adaptive function. At this time, the uninterruptible power supply system can only accept the phase</p>

sequence of L2 delayed by L1 by 120 degrees, and L3 delayed by L2 by 120 degrees.

**EN:** Enable the phase adaptive function. At this time, the uninterruptible power supply system can accept inputs L1 , L2 , and L3 with the same phase angle or phase sequence. L2 delays L1 by 120 degrees, L3 delays L2 by 120 degrees, and L3 delays L2 by 240 degrees.

### 3-7-2. 30K

#### List of setting procedures represented by parameter 1 :

serial number	illustrate	bypass / no output	AC	ECO	CVCF	Battery	Battery test
01	The output voltage	Y*					
02	Output frequency	Y					
03	Allowable voltage range of bypass	Y					
04	Allowable frequency range of bypass	Y					
05	ECO mode activation / deactivation	Y					
06	ECO mode	Y					
07	Allowable frequency range setting in ECO mode	Y					
08	Bypass mode setting	Y	Y				
09	Battery maximum power time setting	Y	Y	Y	Y	Y	Y
10	Inverter output parallel function	Y					
11	reserve	Reserved for future use					
12	N wire connection check warning	Y	Y	Y	Y	Y	Y
13	Battery voltage calibration	Y	Y	Y	Y	Y	Y
14	Charging voltage adjustment	Y	Y	Y	Y	Y	Y
15	Inverter A voltage adjustment		Y		Y	Y	
16	Inverter B voltage adjustment		Y		Y	Y	
17	Inverter C voltage adjustment		Y		Y	Y	
18	Output A voltage calibration		Y		Y	Y	
19	Output B voltage calibration		Y		Y	Y	
20	Output C voltage calibration		Y		Y	Y	

\*Y indicates that the program can be set in the corresponding mode.

Note : All setting changes are saved only when the UPS has a battery connected and is shut down normally. ( Normal UPS shutdown refers to opening the input circuit breaker in bypass or no output mode )

#### 01: Output voltage

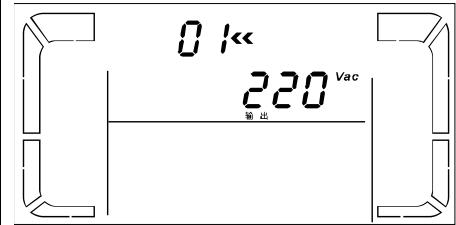
Panel display	set up
	<b>Parameter 3 : Output voltage</b> You can select the following output voltage with parameter 3 : <b>208:</b> The default output voltage is 208Vac <b>220:</b> Default output voltage is 220Vac <b>230:</b> Default output voltage is 230Vac <b>240:</b> The default output voltage is 240Vac

#### ● 02: Output frequency

Panel display	set up
---------------	--------

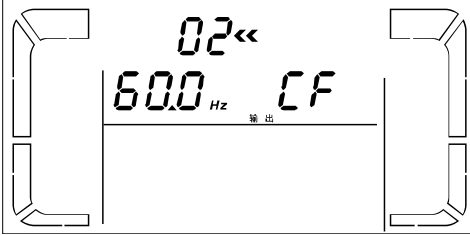
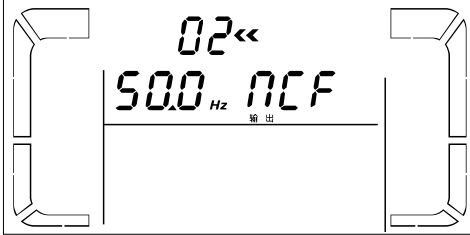
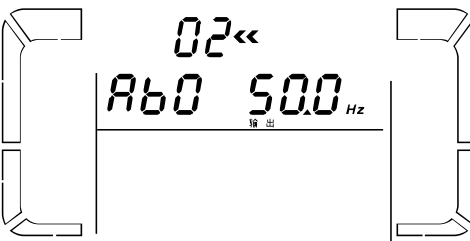
<p style="text-align: center;"><b>60 Hz, CVCF mode</b></p> 	<p><b>Parameter 2 : Output frequency</b> Used to set the output frequency. Here, parameter 2 has the following three options: <b>50.0Hz:</b> The output frequency is set to 50.0Hz. <b>60.0Hz:</b> The output frequency is set to 60.0Hz. <b>ATO:</b> If this option is selected, the output frequency will depend on the mains frequency of the last normal UPS operation. If the mains frequency is between 46Hz and 54Hz , the output frequency will be set to 50.0Hz ; if it is between 56Hz and 64Hz , the output frequency will be set to 60.0Hz . ATO is the default value.</p>
<p style="text-align: center;"><b>50 Hz, normal mode</b></p> 	<p><b>Parameter 3 : Frequency mode</b> Set the output frequency of CVCF mode and non- CVCF mode. Here, parameter 3 has the following 2 options: <b>CF:</b> Set the UPS to CVCF mode. If this option is selected, the output frequency will be fixed at 50Hz or 60Hz according to the setting of parameter 2 . The allowed input frequency range is 46Hz to 64Hz . <b>NCF:</b> Set the UPS to normal mode ( non- CVCF mode ) . If this option is selected, the output frequency will be 50Hz when the input frequency falls within the range of 46~54 Hz , or 60Hz when the input frequency falls within the range of 56~64 Hz , according to the setting of parameter 2 . If it is set to 50 Hz according to parameter 2 , when the input frequency is not within the range of 46~54 Hz , the UPS will enter battery mode; if it is set to 50 Hz according to parameter 2 , when the input frequency is not within the range of 56~64 Hz When within range, the UPS will enter battery mode.</p>
<p style="text-align: center;"><b>ATO</b></p> 	<p>* If parameter 2 is set to ATO , parameter 3 will display the current frequency.</p>

Note : Under the operation of a single machine, there will be a bypass output phenomenon for a short period of time after the machine is turned on. Therefore, in order to avoid damage to the connected load, it is strongly recommended to add an external output relay board in applications operating in variable frequency mode.

● **03: Allowable voltage range of bypass**

<p><b>Panel display</b></p> 	<p><b>set up</b></p> <p><b>Parameter 2 :</b> Set the minimum voltage value allowed in bypass mode. The setting range is 110V to 209V , and the default value is 110V . <b>Parameter 3 :</b> Set the maximum voltage value allowed in bypass mode. The setting range is 231V to 276V , and the default value is 264V .</p>
---	---

● **04: Allowable frequency range in bypass mode**

<p><b>Panel display</b></p> 	<p><b>set up</b></p> <p><b>Parameter 2 :</b> Set the minimum allowable frequency in bypass mode. 50 Hz system: The setting range is from 46.0Hz to 49.0Hz . 60 Hz system: The setting range is from 56.0Hz to 59.0Hz . The default value is 46.0Hz/56.0Hz . <b>Parameter 3 :</b> Set the maximum allowable frequency in bypass mode. 50 Hz : The setting range is from 51.0Hz to 54.0 Hz . 60 Hz : The setting range is from 61.0Hz to 64.0Hz .</p>
---	---

The default value is 54.0Hz/64.0Hz .

● **05: ECO mode activation / deactivation**

Panel display	set up
	<p><b>Parameter 3</b> : Enable or disable the ECO function. Here, you have the following 2 options:  <b>DIS</b>: Disable ECO function.  <b>EN</b>: Enable ECO function.            Even if the ECO function is disabled, You can still set the allowable voltage range and allowable frequency range in ECO mode; however, these range settings will not take effect until the ECO function is enabled.</p>

● **06: Allowable voltage range in ECO mode**

Panel display	set up
	<p><b>Parameter 2</b> : <b>Minimum allowable voltage</b> in ECO mode. The setting range is -5% to -10% of the rated voltage .  <b>Parameter 3</b> : <b>Maximum allowable voltage</b> in ECO mode. The setting range is +5% to +10% of the rated voltage .</p>

● **07: Allowable frequency range of ECO mode**

Panel display	set up
	<p><b>Parameter 2</b> : Set the minimum allowable frequency of ECO mode.            50 Hz system: The setting range is from 46.0Hz to 48.0Hz .            60 Hz system: The setting range is from 56.0Hz to 58.0Hz .            The default value is 48.0Hz/58.0Hz .  <b>Parameter 3</b> : Set the maximum allowable frequency of ECO mode.            50 Hz: The setting range is from 52.0Hz to 54.0 Hz .            60 Hz: The setting range is from 62.0Hz to 64.0Hz .            The default value is 52.0Hz/62.0Hz .</p>

● **08: Bypass mode setting**

Panel display	set up
	<p><b>Parameter 2</b> :  <b>OPN</b> : Allow entering bypass mode. When this option is selected, the UPS will determine how to perform bypass mode based on the bypass function enable / disable settings.  <b>FBD</b> : Not allowed to enter bypass mode. When this option is selected, the UPS will not enter bypass mode under any circumstances.  <b>Parameter 3</b> :  <b>ENA</b> : Bypass function enabled. When this option is selected, bypass mode will be enabled.  <b>DIS</b> : Disable bypass function. When this option is selected, the UPS will be allowed to enter bypass mode automatically, but manual bypass mode will not be allowed. Manual bypass mode refers to the operation of manually putting the UPS into bypass mode, such as pressing the &lt;OFF&gt; button in AC mode and trying to put the UPS into bypass mode.</p>

● **09: Battery maximum power supply time setting**

Panel display	set up
---------------	--------

	<p><b>Parameter 3 :</b>  <b>000~999:</b> Set the maximum battery power supply time, the setting range is from 0 minutes to 999 minutes. When the time is up, the UPS will automatically shut down to protect the battery from reaching a low voltage position. The default value is 990 minutes.  <b>DIS:</b> Disable the battery discharge protection function and the power supply time will depend on the battery power.</p>
--	---

● **10:** Inverter output parallel function

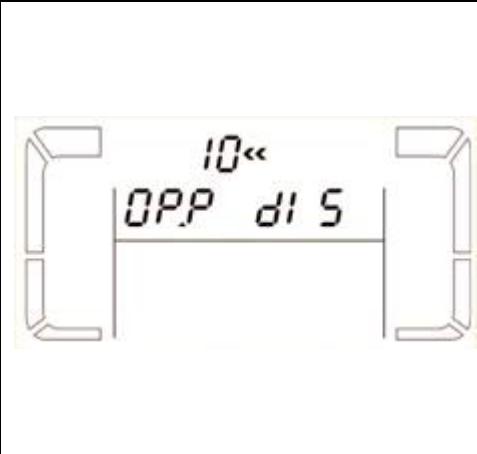
Panel display	set up
	<p>When the output is not set to single-phase output, this option will be retained and "RES" will be displayed in the position of parameter 2 .</p>
	<p>Parameter <b>2:</b>  <b>OP.P:</b> Set to three-phase inverter output parallel function  Parameter <b>3:</b>  <b>DIS:</b> Disable the inverter output parallel function . If you select this option, please do not connect the three-phase inverter output. This is the default value. .  <b>EN:</b> The startup parallel function allows the outputs of three-phase inverters to be connected to obtain 100% of the total power output of one phase. When this function is enabled, the outputs of the inverters must be connected together, and the JS5 must be shorted to achieve a single-phase output.</p>

- **11:** Reserved

Panel display	set up
	Reserved for future use by other settings

- **12: N line connection check warning**

Panel display	set up
	<p><b>NL:</b> Display <b>N line connection check function</b></p> <p><b>Parameter 3:</b></p> <p><b>DIS:</b> If the N- line connection check function is disabled , the UPS will not detect whether the N -line is connected or not.</p> <p><b>ATO:</b> When this item is selected, the UPS will automatically detect whether the N line is connected. When it detects that the N line at the input terminal is not connected, an alarm sound will be generated. If the UPS is powered on, it will enter the battery discharge mode. When the N line is not connected, When detected again, the alarm sound will be automatically muted and the UPS will automatically return to normal operation.</p> <p><b>CHE:</b> When this item is selected, the UPS will automatically detect whether the N line is connected. When it detects that the N line at the input terminal is not connected, an alarm sound will be generated. If the UPS is powered on, it will enter the battery discharge mode. When the N line is not connected, When detected again, the alarm sound <b>will not be</b> automatically muted, and the UPS will <b>not</b> automatically return to normal operation.</p> <p>At this time, if you want to cancel the alarm sound and return the UPS to normal operation, first enter this menu, press the "Enter" key to make "CHE" flash, and then press the "Enter" key again to start the N line detection action. If the N line has been detected at this time, the alarm sound will be muted. The UPS will also switch to normal operation. If the N line has not been detected yet, the UPS will still generate the alarm sound and maintain it at the last setting. state until the next manual detection action is executed. CHE is the default value.</p>

- **13: Battery voltage calibration**

Panel display	set up
	<p><b>Parameter 2 :</b> Select &lt;Add&gt; _ or &lt;Sub&gt; <b>to</b> calibrate battery voltage.</p> <p><b>Parameter 3 :</b> The voltage range is from 0V to 9.9V , and the default value is 0V .</p>

- **14: Charger voltage calibration**

Panel display	set up

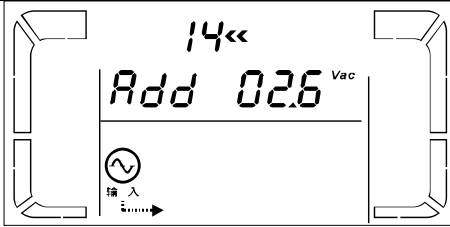

**Parameter 2 :** Select <Add> \_ or <Sub> **to** calibrate the charger voltage.

**Parameter 3 :** The voltage range is from 0V to 9.9V , and the default value is 0V .

**Note:**

- \* Before performing voltage calibration, be sure to disconnect all batteries to measure the correct charging voltage.
- \* We strongly recommend that you leave the default value (0V) unchanged. If you need to change it, be sure to meet the battery specifications.

● **15: Inverter A voltage adjustment**

Panel display	set up
	<p><b>Parameter 2 :</b> Select &lt;Add&gt; _ Or &lt;Sub&gt; to set <b>the</b> inverter voltage adjustment method .</p> <p><b>Parameter 3 :</b> The voltage range is from 0V to 9.9V , and the default value is 0V .</p>

● **16: Inverter B voltage adjustment**

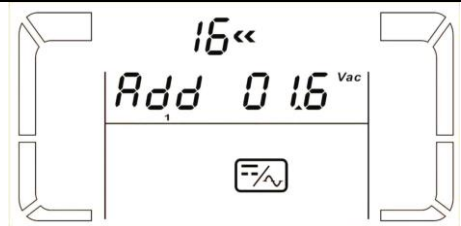
Panel display	set up
	<p><b>Parameter 2 :</b> Select &lt;Add&gt; _ Or &lt;Sub&gt; <b>to</b> set the inverter voltage adjustment method .</p> <p><b>Parameter 3 :</b> The voltage range is from 0V to 9.9V , and the default value is 0V .</p> <p>* The number 1 will be <i>Add</i> displayed on the LCD panel. or <i>Sub</i> The lower part represents the voltage of inverter B.</p>

● **17: Inverter C voltage adjustment**

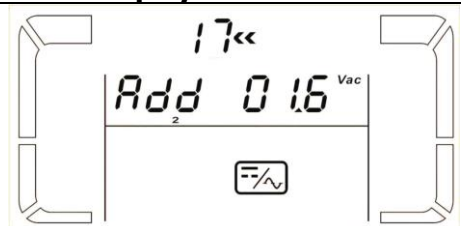
Panel display	set up
	<p><b>Parameter 2 :</b> Select &lt;Add&gt; _ Or &lt;Sub&gt; <b>to</b> set the inverter voltage adjustment method .</p> <p><b>Parameter 3 :</b> The voltage range is from 0V to 9.9V , and the default value is 0V .</p> <p>* The number 2 will be displayed on <i>Add</i> the LCD panel. or <i>Sub</i> The lower part represents the voltage of inverter C.</p>

● **18: Output A voltage calibration**

Panel display	set up
	<p><b>Parameter 2 :</b> Always display <b>OP.V</b> represents the output voltage .</p> <p><b>Parameter 3 :</b> Displays the internal calibration value of the output voltage . The calibrated value can be provided through the " <b>Up</b> " or " <b>Down</b> " <b>key</b> based on the data detected by the external voltage detection instrument . The calibrated value can be obtained after pressing " Enter" key will take effect directly and immediately, and the calibration value range needs to be within +/-9V , and this function is usually applied to parallel connection.</p>

● **19: Output B voltage calibration**

Panel display	set up
	<p><b>Parameter 2 :</b> Always display <b>OP.V</b> represents the output voltage .</p> <p><b>Parameter 3 :</b> Displays the internal calibration value of the output voltage . The calibrated value can be provided through the " <b>Up</b> " or " <b>Down</b> " <b>key</b> based on the data detected by the external voltage detection instrument . The calibrated value can be obtained after pressing " Enter" key will take effect directly and immediately, and the calibration value range needs to be within +/-9V , and this function is usually applied to parallel connection.</p> <p>* The LCD panel will display the number 1 below <i>OPU</i> to indicate the voltage of output B.</p>

● **20: Output C voltage calibration**

Panel display	set up
	<p><b>Parameter 2</b> : Always display <b>OP.V</b> represents the output voltage .</p> <p><b>Parameter 3</b> : Displays the internal calibration value of the output voltage . The calibrated value can be provided through the " <b>Up</b> " or " <b>Down</b> " <b>key</b> based on the data detected by the external voltage detection instrument . The calibrated value can be obtained after pressing " Enter" key will take effect directly and immediately, and the calibration value range needs to be within +/-9V , and this function is usually applied to parallel connection.</p> <p>* The number 2 will be displayed on the LCD panel below <b>OPU</b> to indicate the voltage of output C.</p>

### 3-8. Description of operation mode / status

the LCD display under various operating modes or UPS status :

- (1) If the UPS is operating normally , the LCD will display 4 screens in sequence, which are the input voltage and frequency of the 3 phases (L1, L2, L3) .
- (2) If the parallel UPS system is successfully installed , the LCD will display an additional screen containing " **PAR** " in parameter 2 , and a number will be automatically assigned in parameter 3 ( please refer to the screen display below ) . The main UPS will default to " **001** " Parallel UPSs will be awarded "002" or "003" in sequence. , these default numbers will dynamically change according to the operation conditions.

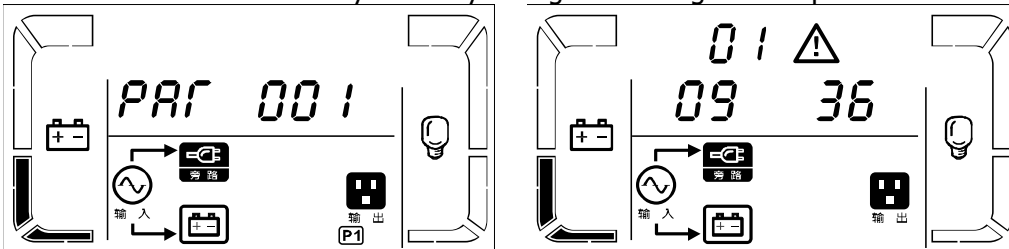

Parallel display

warning display

- (3) If the UPS fails, the LCD will display one more warning screen. In the warning display screen, up to three fault code screens can be displayed. The fault status can be queried in the chapter of the fault table .

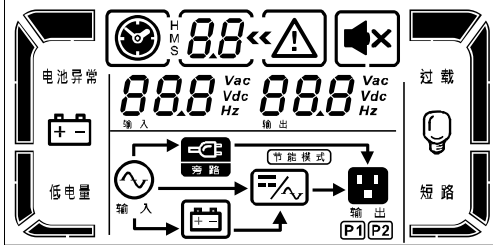
Operation mode / status		
UPS starts	illustrate	When the UPS is started , the following screen will be entered for a few seconds as the starting screen. At this time, the CPU and system are starting.
	LCD display content	
No output mode	illustrate	when When L1 exceeds the acceptable range or the bypass is closed ( or prohibited ) , the UPS will enter the no-output mode after being started,

which means the UPS has no output and the alarm will sound every 2 seconds .

LCD display content

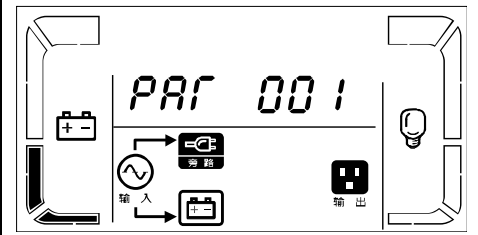
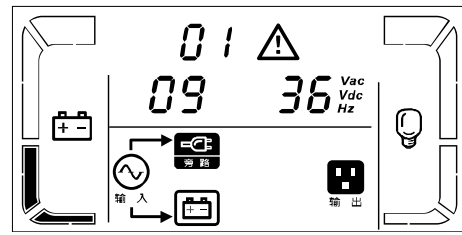
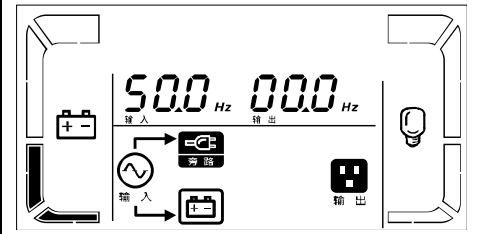
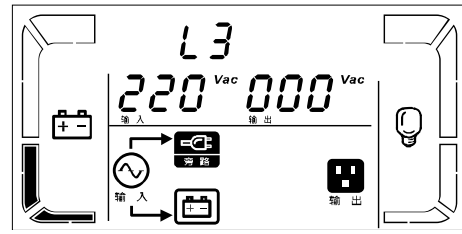
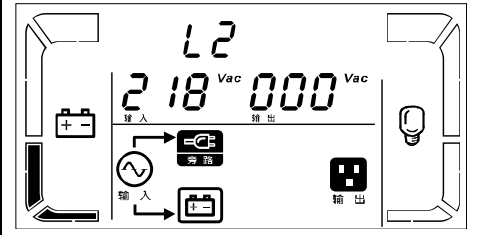
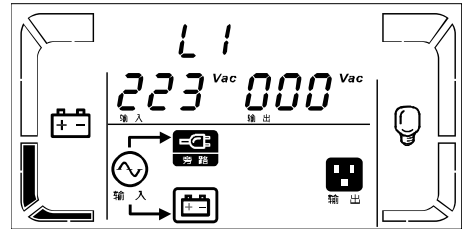

AC mode	illustrate	When the input voltage is within the allowable range, the UPS can provide stable pure AC power output. When the UPS is in AC mode, it charges the battery.
	LCD display content	
ECO mode	illustrate	When the input voltage is within the allowable voltage range and the ECO mode is enabled, the UPS will bypass the voltage to the output terminal to achieve energy saving.
	LCD display content	
CVCF mode	illustrate	When the output frequency is set to "CF" state, the UPS can stably set the output frequency at 50 Hz or 60 Hz according to your settings. In this mode, the UPS will not have a bypass output, but the battery will still be charged.

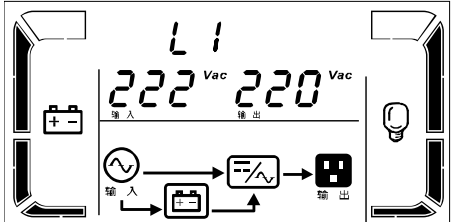
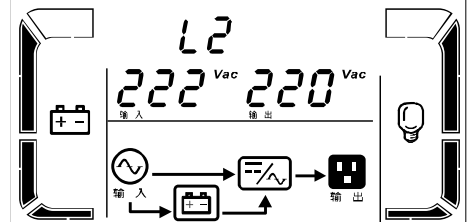
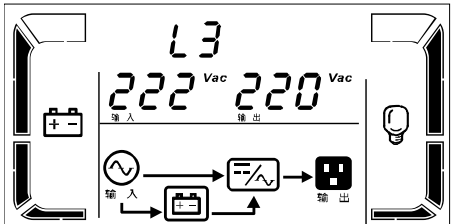
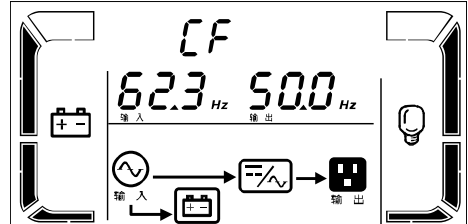
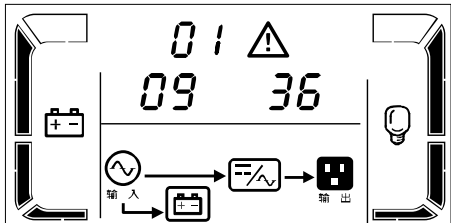
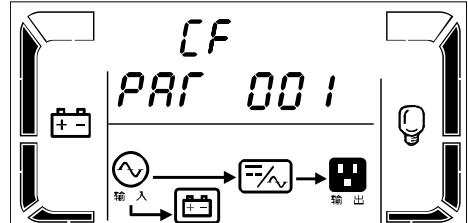
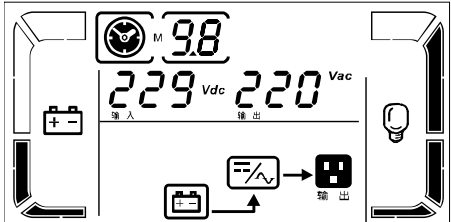
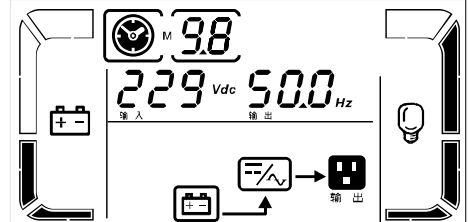
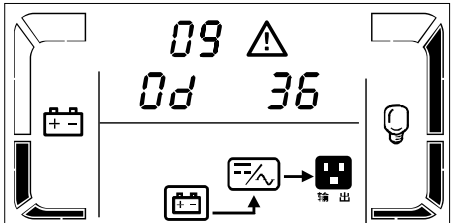
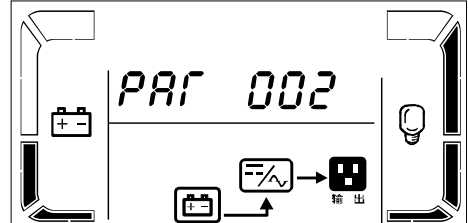
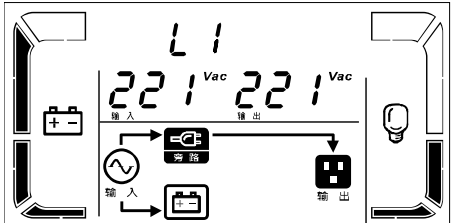
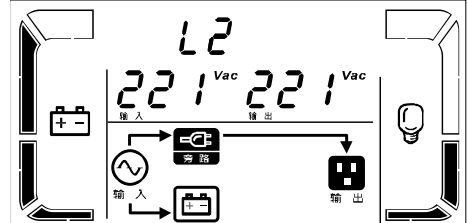
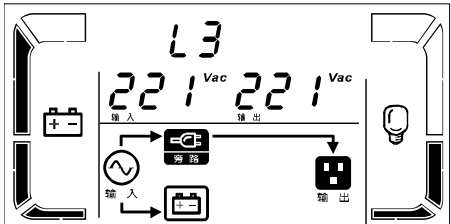
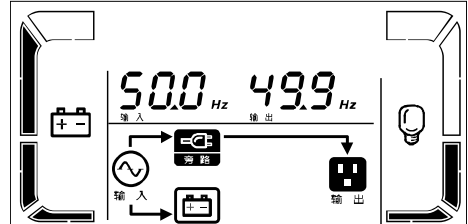
	LCD display content		
			
			
battery mode	illustrate	<p>When the input voltage / frequency is not within the allowable range or there is a power outage, the UPS will be powered by battery power and the alarm will sound every 4 seconds .</p>	
	LCD display content		
			
Bypass mode	illustrate	<p>When the input voltage is within the allowable range and the bypass function is enabled, If the UPS is turned off , the UPS will enter bypass mode. At this time, the alarm will sound every 2 minutes .</p>	
	LCD display content		
			

battery test	illustrate	<p>When the UPS is in AC mode or CVCF mode, press the &lt;Test&gt; button for more than 0.5 seconds, and the UPS will perform a &lt;Battery Test &gt; after a beep . The indicator line between the I/P icon and the inverter indicator will flash. The purpose of this operation is to test the current status of the battery.</p>	
	LCD display content		
warning status	illustrate	<p>When the UPS fails but can still operate normally, an additional screen will be displayed on the LCD panel to display the warning status. In the warning display, <math>\triangle</math>the icon will flash, and up to three warning codes can be displayed, and each number represents a warning condition. You can know what kind of condition it is from the warning code table.</p>	
	LCD display content		
fault status	illustrate	<p>When the UPS fails, the inverter will be locked and unable to operate, and the icon on <math>\triangle</math>the LCD panel will flash and a fault code will be displayed. Please refer to the fault code table for detailed fault conditions.</p>	
	LCD display content		

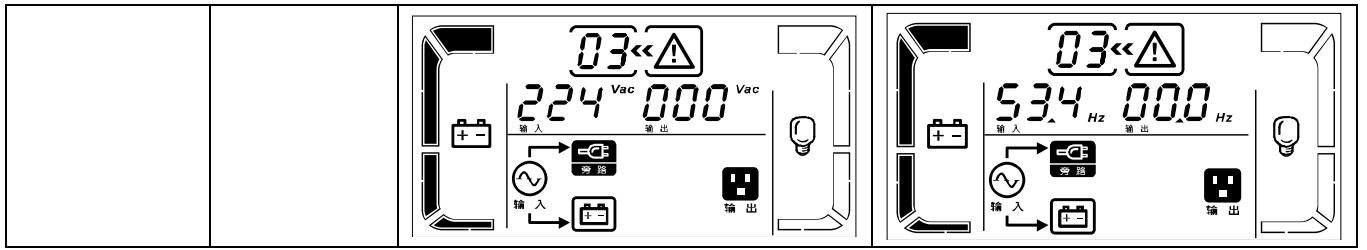

### 3-9.Fault code \_

#### 3-9-1. 10~20K fault codes













error code	Failure event	Illustration	error code	Failure event	Illustration
01	Bus start failed	none	1A	negative power failure	none
02	Bus voltage too high	none	twenty one	Battery SCR short circuit	none
03	Bus voltage is low	none	twenty four	Inverter relay short circuit	none
04	bus unbalanced	none	29	The battery fuse is damaged in battery mode	none
06	Rectifier overcurrent	none	31	Parallel connection failed	none
11	Inverter soft start failed	none	36	The parallel output current does not flow equally.	none
12	Inverter voltage is too high	none	41	overheat	none
13	Inverter voltage is too low	none	43	overload	过载
14	Short circuit at the inverter output	短路	46	UPS operation does not match the model	none

#### 3-9-2. 30K fault code

error code	Failure event	Illustration	error code	Failure event	Illustration
01	Bus start failed	none	1A	Inverter A negative power fault	none
02	Bus voltage too high	none	1B	Inverter B negative power fault	none
03	Bus voltage is low	none	1C	Inverter C negative power fault	none
04	bus unbalanced	none	twenty one	Battery SCR short circuit	none
06	Rectifier overcurrent	none	twenty four	Inverter relay short circuit	none
11	Inverter soft start failed	none	29	The battery fuse is damaged in battery mode	none
12	Inverter voltage is too high	none	31	Parallel communication failed	none

13	Inverter voltage is too low	none	36	Parallel output current imbalance	none
14	output terminal A of the inverter ( live wire - neutral wire ) is short-circuited	短路	41	overheat	none
15	The output terminal B of the inverter ( live wire - neutral wire ) is short-circuited	短路	42	DSP communication failed	none
16	C output terminal of the inverter ( live wire - neutral wire ) is short-circuited	短路	43	overload	过载
17	AB output terminal of the inverter ( live wire - live wire ) is short-circuited	短路	46	UPS model setting is incorrect	none
18	BC output terminal of the inverter ( live wire - live wire ) is short-circuited	短路	47	MCU communication failed	none
19	CA output terminal of the inverter ( live wire - live wire ) is short-circuited	短路	48	The two DSP firmware versions are inconsistent	none
			49	Input and output phases are inconsistent	none

### 3-10. Warning indicator









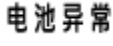

Warning content	Icon ( flashing )	Alarm sound
Battery is low	 low power	One sound per second
overload	 overload	Two beeps per second
The battery is not connected properly	 Battery abnormality	One sound per second
Overcharging		One sound per second
EPO enabled	 EP	One sound per second
Fan failure / overheating	 	One sound per second
Charger failure	 	One sound per second
I/P fuse blown	 	One sound per second
Other warning events ( please refer to Chapter 3-11 )		One sound per second

### 3-11. warning code

warning code	warning event	warning code	warning event
01	Battery not connected	10	The input L1 fuse is damaged
02	The input N wire is not connected or the L2/L3 input fuse is damaged.	twenty one	The offline voltage status of the parallel system is inconsistent
04	Input phase failure	twenty two	Inconsistent bypass settings in parallel systems
07	Battery overcharged	33	Three overloads within 30 minutes caused bypass lockout
08	Battery low	34	Uneven current flow inside the rectifier
09	Overload warning	35	Broken battery fuse
0A	Fan failure	36	Uneven current flow inside the inverter
0B	EPO start	3A	The cover of the maintenance switch is opened
0D	overheating warning	3B	Phase adaptation function failure
0E	Charger failed to charge	3C	Mains power is extremely unbalanced
		3D	Bypass is unstable

## 4. Troubleshooting

When the UPS system is not functioning properly, please follow the table below to try to solve the problem.

problem situation	Possible Causes	Solution
The main power supply is normal, but no indicator light comes on and no alarm sounds.	The AC input power supply may be loose or not connected properly.	Check whether the input wire is loose.
There are  diagram and  The fault code is flashing, and an alarm sounds every second.	EPO function is enabled. The EPO switch is in the "OFF" state or is in an open circuit state.	Please set the setting circuit to a closed state to disable the EPO function.
There are  and  The icon is flashing and an alarm sounds every second.	The external or internal battery connection method is faulty.	Check that all batteries are connected correctly.
There are  and  The icon is flashing and the alarm beeps twice every second.	The UPS is overloaded.	Please remove the excess load from the UPS output terminal.
	The UPS is overloaded, and the UPS is currently supplying power to the equipment directly from the power grid in bypass mode.	Please remove the excess load from the UPS output terminal.
	After multiple overloads in a short period of time, the UPS has been locked in bypass mode and the equipment is directly connected to the main power supply.	the UPS output first , then shut down and restart the UPS system.
The fault code displays 43 and  The icon lights up and the alarm sounds continuously. .	The UPS is overloaded for too long and enters a fault state, and automatically shuts down.	from the UPS output terminal and then restart.
The fault code displays 14 and  The icon lights up and the alarm sounds continuously.	The UPS automatically shuts down due to a short circuit at the output.	Check the wiring of the output terminal to confirm whether there is a short circuit in the device.
the LCD panel, and the alarm sound continues to sound.	the UPS .	Please contact your dealer.
The battery provides backup power for less time than specified.	The battery may not be fully charged.	Please charge for at least 7 hours before checking the battery level. If the battery power is still low, please contact your dealer.
	Battery failure.	Please contact your dealer to request battery replacement.
There are  and  The icon is flashing and an alarm sounds every second.	The fan is stuck or unable to rotate; or the UPS is overheated.	Check the fan and contact your dealer.
The warning code displays 02 and  the icon is flashing, and the alarm sound continues to sound, with one sound every second.	The input N wire is not connected.	Please check and connect the N line of the input end. If the connection condition has been repaired and the alarm sound still does not disappear, please follow the N line detection steps in the LCD settings and enter the menu to manually

		eliminate the alarm sound. If the alarm sound still does not disappear, , please check the input fuse status of L2 and L3 .
	L2 or L3 input fuse blown.	Replace fuse.

## 5.Storage and maintenance

### 5-1 . \_ store

7 hours before storing this product . When storing, it should be placed in an upright position in a dry place. During storage, please perform charging and maintenance according to the following table:

Storage temperature	Charging interval	Charging time
-25°C - 40°C	every 3 months	1 to 2 hours
40°C - 45°C	every 2 months	1 to 2 hours

### 5-2.Maintenance \_

 · This UPS system will use hazardous voltage power during operation; therefore, any maintenance may only be performed by qualified maintenance personnel .

 Even if this product has been removed from the socket ( indoor wiring socket ) i , the internal components are still connected to the built-in battery and are therefore still live and dangerous.

 · When performing any repairs and / or maintenance, in addition to disconnecting the battery, you should also confirm that there is no current inside. In particular, you should confirm that there is no voltage between the connectors of high-capacitance components such as bus capacitors.

 · Only personnel who are familiar with batteries and take appropriate safety measures can perform battery replacement or provide related guidance. Unauthorized personnel should not have access to the battery.

 Before performing any maintenance or repairs, be sure to confirm that there is no voltage between the battery terminals and that a solid ground is present. In this product, the battery circuitry remains connected to the input voltage, so hazardous voltages may still exist between the battery terminals and ground.

 Batteries may cause electric shock and produce relatively high short-circuit currents. When servicing the battery, be sure to remove watches, rings, and any other metal objects from your body, and only use tools with insulated grips.

 When replacing batteries, install the same number and type of batteries.

 Do not throw batteries into fire as they may explode. Waste batteries should be disposed of in accordance with local regulations.

 Do not disassemble or damage the battery. Once the electrolyte contained in the battery leaks, it will cause damage to the skin and eyes, and may even be toxic.

 When replacing a fuse, be sure to use the same type and amperage to avoid fire hazards.

 This UPS system cannot be disassembled.

Warning users:

This is a Class A information product that may cause radio frequency interference when used in a residential environment; in this case the user will be required to take certain appropriate countermeasures.

## 6. Product specifications

model		DTH31-10K ( L )	DTH31-15K ( L )	DTH31-20K ( L )
<b>Capacity *</b>		10000VA/8000W	15000VA/12000W	20000VA/16000W
<b>enter</b>				
voltage range	Minimum switching voltage	110 VAC(LN) $\pm$ 3% at 50% load 176 VAC(LN) $\pm$ 3% at 100% load		
	Minimum recovery voltage	Minimum loss voltage + 10V		
	Maximum conversion voltage	300 VAC(LN) $\pm$ 3% at 50% load 276 VAC(LN) $\pm$ 3% at 100% load		
	Maximum recovery voltage	Maximum loss voltage - 10V		
Frequency Range		4 6 Hz ~ 54 Hz @ 50Hz system 56 Hz ~ 64 Hz @ 60Hz system		
Phase		Three-phase grounding type		
Power Factor		$\geq$ 0.99 at 100% load		
<b>output</b>				
The output voltage		208/220/230/240VAC		
AC voltage range		$\pm$ 1%		
Frequency range ( synchronization range )		4 6 Hz ~ 54 Hz @ 50Hz system 56 Hz ~ 64 Hz @ 60Hz system		
Frequency range ( battery mode )		50 Hz $\pm$ 0.1 Hz or 60Hz $\pm$ 0.1Hz		
overload	AC mode	100%~110%: 10 minutes ; 110%~130%: 1 minute ; >130%: 1 second		
	battery mode	100%~110%: 30 seconds ; 110%~130%: 10 seconds ; >130%: 1 second		
Current peak ratio		3:1max		
harmonic distortion		$\leq$ 2 % @ 100% linear load ; $\leq$ 5 % @ 100% non-linear load		
switching time	Online $\longleftrightarrow$ battery	0 milliseconds		
	Inverter bypass $\longleftrightarrow$	0 milliseconds		
	Inverter $\longleftrightarrow$ ECO	< 10ms		
<b>efficiency</b>				
AC mode		> 89%	>89%	>89%
battery mode		> 86%	>88%	>87%
<b>Battery</b>				
Standard machine	model	12V/9Ah	12V/9Ah	12V/9Ah
	number	20 (18-20 adjustable )	2 x 20 (18-20 adjustable )	2 x 20 (18-20 adjustable )
	Charging time	Reach 90% capacity in 9 hours		
	Charging current ( maximum value )	1.0A $\pm$ 10%	2.0A $\pm$ 10%	2.0A $\pm$ 10%
	Charging voltage	273 VDC $\pm$ 1%		
Long extension machine	model	Varies according to use		
	number	16-20		
	Charging current ( maximum value )	4.0A $\pm$ 10%	8.0A $\pm$ 10%	8.0A $\pm$ 10%
	Charging voltage	273 VDC $\pm$ 1% ( based on 20 cells )		
<b>Exterior</b>				
Standard machine	Dimensions , depth x width x height (mm)	592X250X576	815X250X826	815X250X826
	Net weight (kgs)	83	164	164
Long extension machine	Dimensions , depth x width x height (mm)	592X250X576	592X250X576	592X250X576
	Net weight (kgs)	28	40	40
<b>environmental conditions</b>				
operating temperature		0 ~ 40°C ( Battery life will be shortened in environments > 25°C )		

Operating humidity	< 95 % and no condensation	
Operating altitude **	<1000m	
noise	Less than 58dB @ 1 Meter	Less than 60dB @ 1 Meter
<b>manage</b>		
Smart RS-232 or USB	Supports Windows® 2000/2003/XP/Vista/2008/7/8 , Linux , Unix , and MAC	
Optional SNMP	Supports power management by SNMP administrator and web browser	

\* When the output voltage is set to 208VAC , the machine will derate the output to 90% .

\*\* If the UPS is installed and used in an environment with an altitude exceeding 1,000 meters, the output power should be calculated to decrease by 1% for every 100 meters .

\*\*\* Product specifications are subject to change without prior notice, please understand.